



MARCH 2024

Original operating instructions for verope[®] special wire ropes





TABLE OF CONTENTS

0	WARNINGS	5
0.1	Putting on PPE (personal protective equipment)	5
0.2	Pictograms - danger and mandatory signs.....	5
1	INTRODUCTION	7
1.0	Information on the manufacturer	7
1.1	Intended use	7
1.2	Reasonably foreseeable misuse	8
1.3	List of special wire ropes for which these operating instructions are valid.....	8
1.4	Target groups.....	9
1.5	Documents.....	9
1.6	Life cycle	11
2	HEALTH, SAFETY AND ENVIRONMENT	11
2.1	Precautionary measures / safety instructions.....	11
2.2	Operational safety measures.....	12
2.3	Medical emergency measures	13
2.4	Safety instructions - risk of fire or explosion.....	13
2.5	Disposal of the product or packaging material.....	13
2.6	Duty of care of the operator.....	13
2.7	Duty of care of the user	13
2.8	Deadlines for periodic inspections.....	14
2.9	Information from ISO 4309	14
3	ROPE SELECTION.....	14
3.1	Definitions	13
3.2	Rope end connections	25
3.3	Guide to rope selection	27
3.4	Technical data.....	32
3.5	Reference to catalog or data sheets	33
3.6	General information	33
4	PACKAGING, TRANSPORT, HANDLING AND STORAGE.....	34
4.1	Product labeling.....	31
4.2	Storage, handling & installation.....	35
5	INSTALLATION	41
5.1	Installation instructions.....	41
5.2	Installation.....	42
5.3	Installation examples	45
5.4	Troubleshooting	50

6	INSPECTION AND PERIODIC MAINTENANCE	52
6.1	Types of inspection.....	52
6.2	Tools required for the inspection.....	53
6.3	Discard criteria.....	54
6.4	Other rope damage.....	57
7	MAINTENANCE	58
7.1	Maintenance of the rope.....	58
7.2	Relubrication of special wire ropes	58
7.3	Removing the ends of broken wires.....	60
7.4	Replacing the rope / dismantling Decommissioning	61
8	WARRANTY / TERMS OF BUSINESS ETC.....	62
9	TRACKING.....	67

0 WARNINGS

0.1 Putting on PPE (personal protective equipment)

Putting on PPE

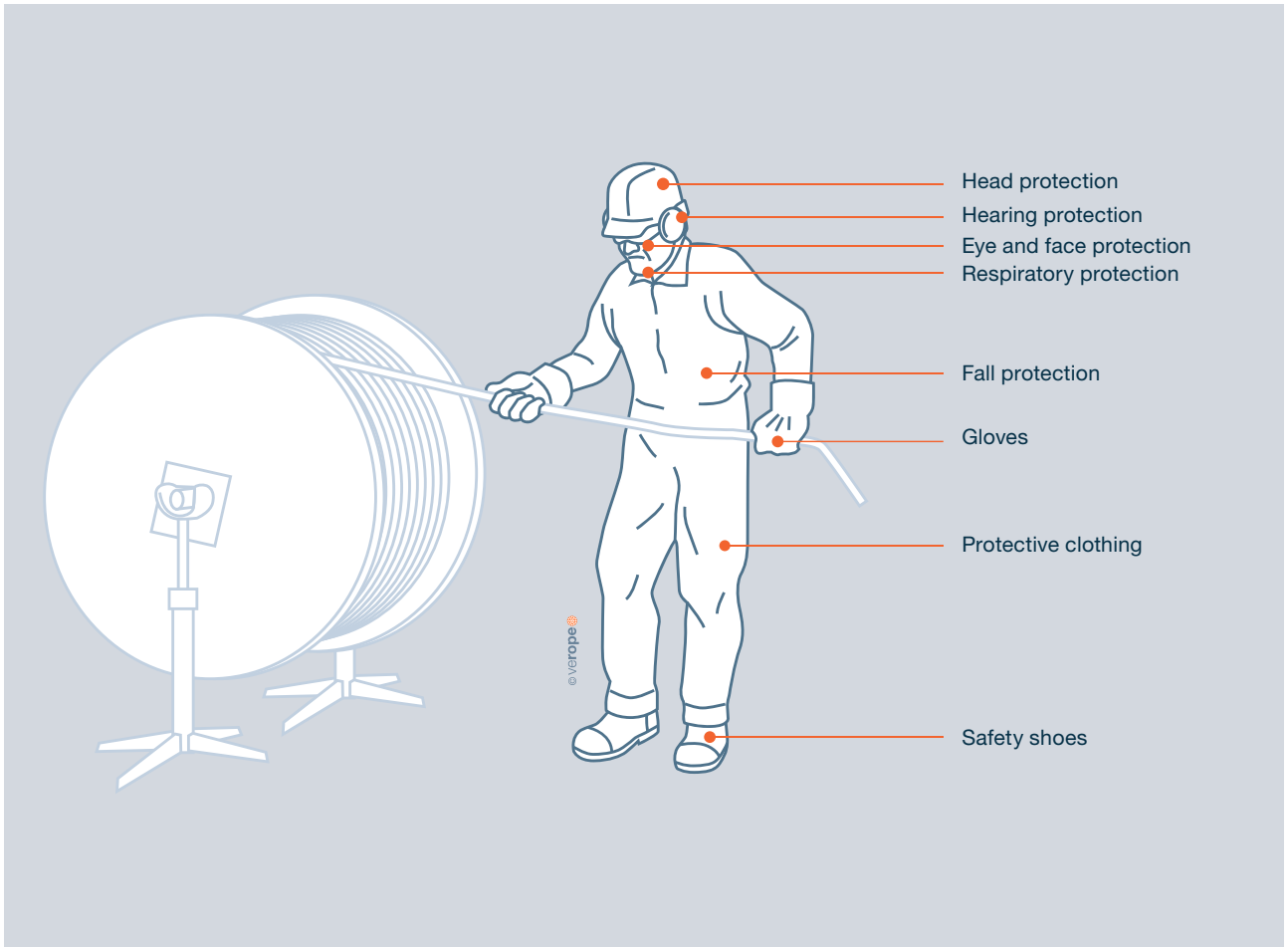

0.2 Pictograms - Danger and mandatory signs

General warnings



Danger / Caution /
General warning



Danger / Caution / Warning
of hand injury



Danger / Caution / Burns



Commandment sign



General mandatory sign



Use hearing protection



Use eye protection



Use foot protection



Use hand protection



Use protective clothing



Use face protection



Use head protection



Use safety vest



Use respiratory protection



Use safety harness

1 INTRODUCTION

1.0 Details of the manufacturer

Name	verope® AG
Adresse	Sankt-Antons-Gasse 4A, 6300 Zug, Switzerland
E-Mail	info@verope.com
Phone	+41 41 72 808 80

1.1 Intended use

Intended use: Ropes as machines or parts of machines may only be used for their intended purpose. All verope® special wire ropes may only be used for lifting purposes as part of hoisting equipment or lifting accessories. Any other use is considered improper and excludes the manufacturer's liability. Proper use also means that the ropes may only be used in compliance with the relevant standards and the specifications of the respective crane manufacturer. Particular attention must be paid to the maximum permissible load and the permissible operating conditions (maximum bending radius, maximum deflection angle, maximum temperature, etc.). Independent reduction of the safety factors specified by the machine by the user is not permitted and, in the worst case, can endanger life and limb and result in additional high damage costs. verope® special wire ropes and their end connections may only be installed in an approved system whose dimensions (e.g. openings, bolts, etc.) are adapted to the respective end connection and rope end. In case of doubt, verope® AG must be consulted. The user must ensure adequate inspection and maintenance of the ropes. If there is any doubt about the suitability of verope® special wire ropes for their intended use, verope® AG must be consulted. If laws or regulations apply in the country of use that go beyond the generally known standards and regulations, these must be observed.



Pierre Verreet, CEO
verope® AG | St. Antons Gasse 4a | CH-6300 Zug ZG – Switzerland
Tel: + 41 (0) 41 72 80 880 | www.verope.com

verope® special wire ropes for general lifting purposes as part of lifting gear or load handling equipment.

1.2 Reasonably foreseeable misuse

Reasonably foreseeable misuse	Possible damage / residual risk
Misuse of the verope® special wire rope or the machine	Can lead to damage or rope breakage
Failure to observe the maximum permissible load and installation conditions	Can lead to premature discarding or rope breakage
Small bending radius, max. deflection angle, etc.	Can lead to premature rope damage, short rope service life and possibly rope breakage
Independent reduction of the safety factors specified by the machine	Can lead to overloading and rope breakage or system failure
Insufficient inspection and maintenance	Can lead to premature rope discard or rope breakage
Improper storage	Can lead to premature discarding or rope breakage
Use of non-galvanized special wire ropes in the offshore sector	Can lead to premature discarding or rope breakage
Use of Lang lay ropes in cargo handling operations	May lead to rope breakage if discard maturity is not recognized
Shock load	May lead to rope breakage if discard maturity is not recognized
Damage due to heat or electrical influences	May lead to premature discard maturity or rope breakage
Working with plastic sheaves or non-metallic sheaves without adjusting the discard criteria	May lead to rope breakage if discard maturity is not recognized

1.3 List of special wire ropes for which these operating instructions are valid

Rotation-resistant verope® rope constructions

Rotation-free ropes have at least 14 outer strands and a steel rope core laid in opposite directions

verotop P
 verotop XP
 verotop
 verotop S
 verotop S+
 verotop E

Rotation-resistant verope® rope constructions

A rotation-resistant rope construction consists of four rope strands, which are only manufactured in a cross lay design.

vero 4

Non-rotation-resistant verope® rope constructions

Non-rotation-resistant ropes have a maximum of 12 outer strands and a steel rope core with the same lay direction as the rope.

verostar 8

veropro 8

veropro 8 RS

veropower 8

veropro 10

verotech 8

verotech 9

verotech 10

verosteel 8

verotower 8

1.4 Target Groups

Target Group	Work areas
End users/consumers	Crane operators, maintenance staff, machine operators, production workers, etc
Fitters	Crane operators, maintenance staff, etc.
Manufacturer	Crane drivers, installers, customers, production employees, etc.

1.5 Documents

- CE Declaration of Conformity
- Dokumentation Beschreibung
- Cable certificates - cable-specific technical data & test data
- Cable data sheets - general cable technical data
- Contract / General conditions - Contains contractually agreed data
- verope® Technical brochure
- verope® Handling brochure
- verope® General catalog
- verope® Terminations brochure



www.verope.com

verope AG
Sankt-Anton-Gasse 4A
6300 Zug - Schweiz

Original EG-Konformitätserklärung für eine Maschine

Werkzeugnis EN 10204 - 2.1

Dokument Nr. | Document No.:

ABXXXXX

Original EG-Declaration of Conformity for a Machine

Certificate EN 10204 - 2.1

Kundennr. | Customer No. | Client No.

CUSTXXXX

Original EG-Declaration de Conformité de Machines

Certificat EN 10204 - 2.1

Ihre Bestellung | Your Order | Votre c

XXXXXX / XXXXXX

im Sinne der EG-Maschinenrichtlinie 2006/42/EG

Hiermit erklären wir, dass die nachfolgend bezeichnete Maschine aufgrund Ihrer Konzipierung und Bauart, sowie der von uns in Verkehr gebrachten Ausführung, den grundlegenden Sicherheits- u. Gesundheitsanforderungen der EG-Maschinenrichtlinie 2006/42/EG sowie den unten aufgeführten harmonisierten und nationalen Normen sowie technischen Spezifikationen entspricht. Bei einer nicht mit uns abgestimmten Änderung der Maschine verliert diese Erklärung ihre Gültigkeit. Diese Erklärung ist nach Inbetriebnahme der Maschine einem Prüf- und Kranbuch beizufügen. Bei Hubseilen und Ketten ist der Kennzeichnungsanhänger an geeigneter Stelle am Hubwerk zu befestigen.

as defined by the Machinery Directive 2006/42/EG

We hereby declare that the equipment sold by us because of its design and construction, as mentioned below, corresponds to the appropriate basic requirements of safety and health of the corresponding EG-Machinery Directive 2006/42/EG as well as to the below mentioned harmonized and national norms as well as technical specifications. In case of any modification of the equipment, not being agreed upon with us, this declaration becomes invalid. This Declaration has to be added to a logbook after bringing the machine into service. For lifting ropes and chains the identification tag have to be attached at the lifting unit.

au sens de la directive CE sur les machines 2006/42/EG

Par la présente, nous déclarons que la machine indiquée ci-dessous, de part sa conception et type de construction, ainsi que la version que nous mettons sur le marché, satisfait à l'ensemble des dispositions pertinentes de la Directive Machine EN 2006/42/CE des normes harmonisées et nationales ainsi que des spécifications techniques ci dessous. Tout modification de la machine sans notre consentement préalable entraine la nullité de cette présente déclaration. Cette déclaration doit être ajoutée au libre de contrôle après mise en service de la machine. Pour les cordes et chaînes de levage, l'étiquette d'identification doit être attachée à l'élévatrice.

Angewendete harmonisierte bzw. noch nicht harmonisierte Normen:

Applied harmonized or not yet harmonized standards:

Normes appliquées harmonisées et/ou pas encore harmonisées:

DIN EN 12385-1 bis 10:2009-01

Drahtseil aus Stahldrähten Anforderungen / Begriffe

DIN EN 12385-1 to 10:2009-01

Ropes from Steelwires Requirements

DIN EN 13411-1 bis 9

Lieferbedingungen

DIN EN 13411-1 to 9

Terms Terms of Delivery

Endverbindungen für Drahtseile aus Stahldraht

Terminations for steel wire ropes

Sicherheit

Safety

Mge (Stück)	Artikel
Qty (Unit)	Item
Qté (Pièce)	Article

150 Meter	PO814G19RO	Veropower 8, 14mm, galv. 1960, RHOL Reel-No. 3105-1
-----------	------------	--

Spezialdrahtseile für allgemeine Hebezwecke / Special wire ropes for general lifting purposes

Ort u. Ausstellungsdatum, Name und Unterschrift oder gleichwertige Kennzeichnung des Befugten

Place and Date of issue, name and signature or equivalent marking of authorized person

Lieu et date d'émission, nom et signature du signataire autorisé

Dokumentationsverantwortlicher:
Responsibility for documentation:
Responsible pour documentation:



St. Antons Gasse 4a
CH-6300 Zug ZG
Switzerland
Tel: +41 41 72 80 880

Pierre Verreet

Signature

Zug den 24.01.19. Pierre Verreet - CEO

Danielle Mistconi / VAG
QM – Manager
St. Anton Gasse
CH-6300 Zug AG
Misticoni@verope.com

1.6 Life cycle of verope® special wire ropes

Transportation

Installation

Operation

Maintenance

Dismantling

Disposal

2 HEALTH, SAFETY AND ENVIRONMENT

2.1 Precautionary measures / safety instructions



verope® special wire ropes are designed and manufactured using the latest technology and in accordance with current safety regulations. The verope® product can be used safely if the instructions given in this manual are strictly adhered to. verope® accepts no responsibility for personal injury or damage to property resulting from the use of the products in disregard of the instructions given in this manual.

verope® special wire ropes may only be used, operated and maintained by authorized and specially trained persons. Read and follow the instructions in this operating manual in order to operate the system safely and to use the verope® special wire rope safely. Do not carry out any modifications or repairs to the device yourself. Always observe the current safety regulations.

Before using verope® special ropes, please observe the following points:

- Familiarize yourself with the work to be carried out by reading the user manual or operating instructions.
- Familiarize yourself with the safety precautions (emergency stop, escape routes, etc.) on site..
- Find out about the protective and safety features of the equipment and the application.



Before starting work, check the following points:

- The operating switches are in the OFF position, and adequate measures (fuses, panels, shut-off devices, etc.) have been taken to prevent accidental start-up of the system during work.
- Ensure safety during work by knowing the correct machine movement (direction of drum rotation, etc.).
- Switch off the system before starting work.
- Observe the instructions given in the relevant warnings during work.
- Make sure that every colleague, helper or other personnel is informed about potential dangers that may occur during or as a result of the work.
- Always work with the utmost concentration and anticipation.





- If protective devices have to be partially or completely removed to carry out special technical repair work, they must be removed at all times.
- Check that no tools or parts are left in the system.
- Make sure that the installation and the rope used operate safely.

2.2 Operational safety measures

When working with verope® special wire ropes, e.g. cutting, welding, grinding or cleaning, dust and vapors may be produced which can be hazardous to health.

Observe the locally applicable safety guidelines and wear appropriate personal protective equipment (PPE) at all times.



Use hearing protection



Use eye protection



Use face protection



Use foot protection



Use hand protection



Use protective clothing



Use head protection



Use safety vest

2.3 Medical emergency measure

In case of inhalation of hazardous substances:

Remove affected person to fresh air and get emergency medical help immediately.

In case of skin contact:

Wash affected areas directly with soap and water.

In case of contact with eyes:

Flush eyes thoroughly with running water. Get medical attention immediately.

If swallowed:

Give first aid and get emergency medical help immediately.

2.4 Safety instructions - risk of fire or explosion



In principle, the steel components of the rope pose only a low risk of fire or explosion. The safety data sheets for any plastics and lubricating greases present in the ropes must be observed accordingly and are available from verope® AG.

2.5 Disposal of the product or packaging material

Ensure that the ropes are handled in an environmentally friendly manner on site and when disposing of the packaging material and used ropes. To prevent environmental damage and injury: Do not leave any packaging material, ropes, tools or aids in the environment.

2.6 Duty of care of the operator

To ensure safe operation, the user of the machine must fulfill the following obligations:

- Regular maintenance
- Carry out safety instructions
- Carry out training
- etc.

2.7 Duty of care of the user

To ensure safe operation, the user of the machine must fulfill the following obligations:

- Read and follow the operating instructions
- Keep the workplace clean
- Wear the necessary protective equipment
- etc.

2.8 Deadlines for recurring inspections

Test part	Interval	Test type	To be tested by
verope® special wire rope	daily	Visual inspection	User/machine operator
verope® special wire rope	daily	Inspection	Qualified person
installation	regularly*	Inspection	Competent person

Determination of the inspection intervals in accordance with ISO 4309 or the competent expert.

2.9 Information from ISO 4309

Regular inspection of the wire rope

Thorough visual inspection including measurement of the rope and, where practicable, assessment of the internal condition of the rope.

Note 1 to entry: Where practicable, this inspection may include a magnetic rope inspection carried out by a competent person for wire rope inspection who is familiar with the use of MRI equipment and the evaluation of reference values.

Qualified person for wire rope inspection

Person with expertise and experience in the field of wire ropes on cranes and winches who is qualified to assess the condition of the rope, to assess whether the rope may remain in operation and to determine the maximum interval between inspections.

3 ROPE SELECTION

3.1 Definitions

Rope technology basics - All about the wire

Raw material

Rope wires are usually made from killed, unalloyed carbon steel with a prescribed degree of purity. The carbon content is between 0.4 % and 1 %, the manganese content between 0.3 % and 1 %, the silicon content between 0.1 % and 0.3 % and the phosphorus and sulphur contents each below 0.45 %.

Manufacture

Wire rod with a diameter of around 6 mm to 9 mm is first produced by hot forming. This is then brought to the desired strength and diameter in a cold forming process by drawing or rolling.

Wire surfaces

Galvanized wires are given a zinc coating when they pass through a bath of liquid zinc. If the wire is not further drawn after this treatment, it is called „final galvanized“. If the wire cross-section is further reduced after galvanizing, the wire is called „not finally galvanized or galvanized drawn“. Bare rope wires without coating are marked with the letter U, rope wires with zinc coatings of class B or A are marked with the letters B or A.

Wire forms

A distinction is made between shaped and profiled wires. A shaped wire is a wire with a round cross-section, a profiled wire is any wire with a non-circular cross-section. There are oval wires, flat wires, Z and S profile wires, waist wires, wedge wires and triangular wires. Profile wires are produced by drawing or rolling.

Wire tensile strength

The tensile strength of a wire is defined as the bearable tensile force in the longitudinal direction of the wire, divided by the wire cross-section. The nominal wire tensile strength is a theoretical value that the tensile strength of the wire must not fall below and may only exceed within defined limits. Rope wires with nominal strengths of 1770 N/mm², 1960 N/mm², 2060 N/mm², 2160 N/mm², 2260 N/mm² and 2360 N/mm² are usually used in modern wire ropes.

Wire hardness

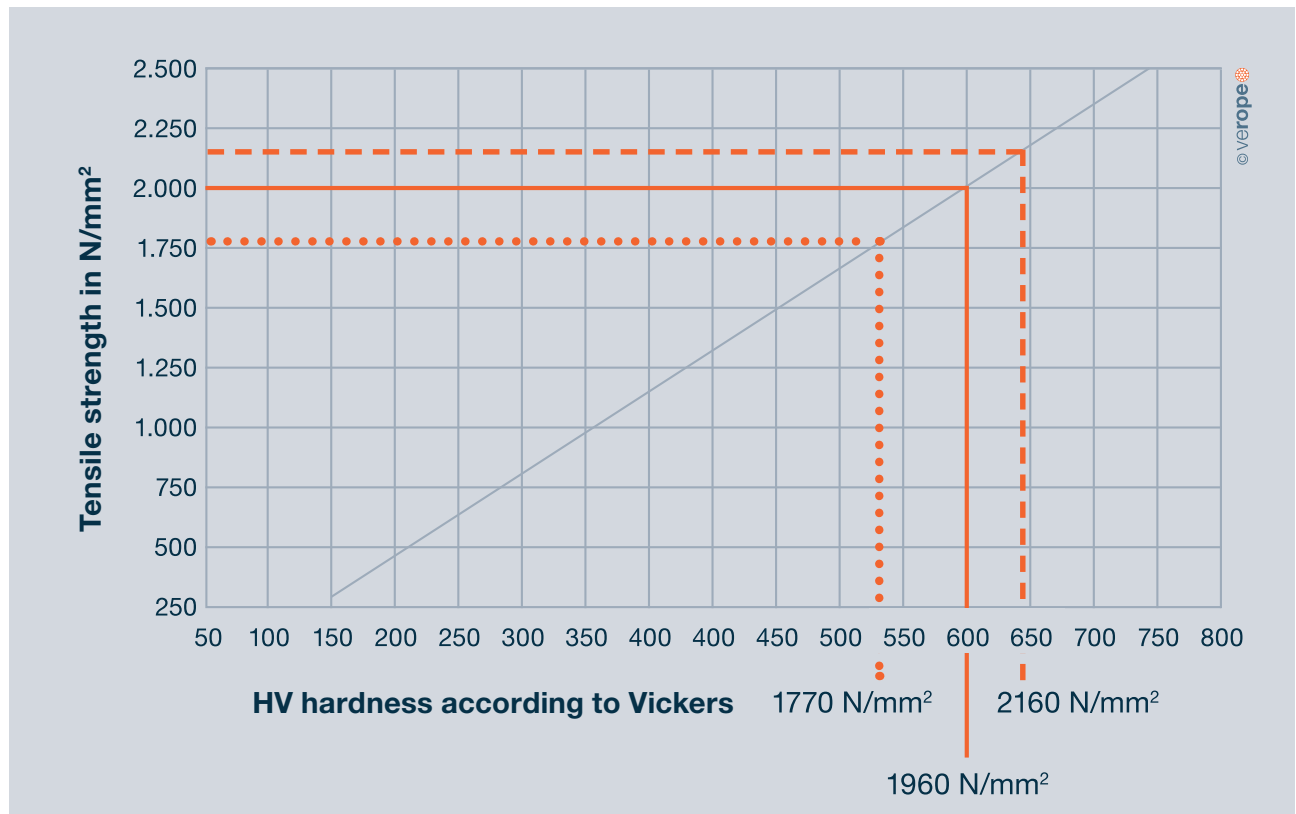

Wire drawing process

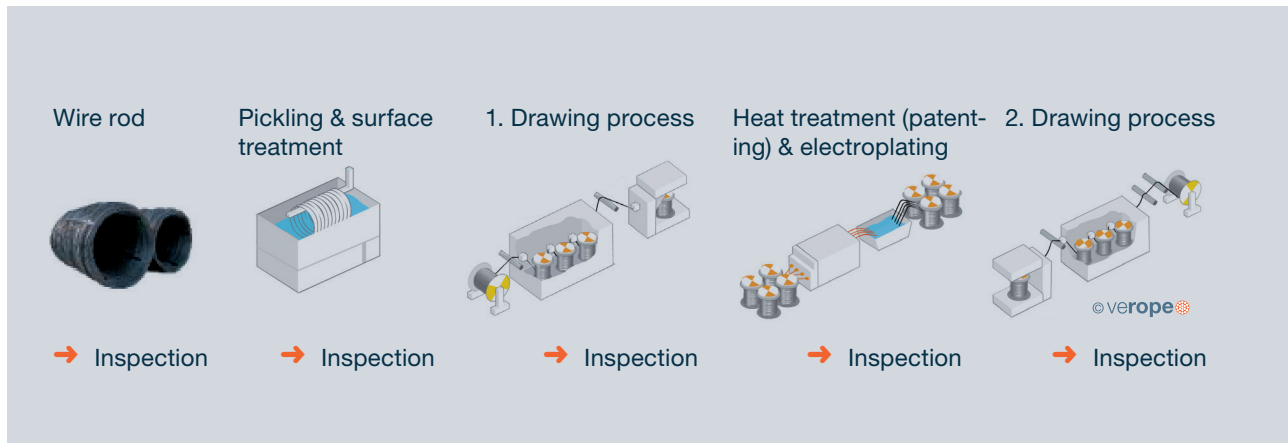

Unique verope® special wire ropes:

- high quality raw material
- modern design
- competent production & innovative rope testing
- unique design
- experience of specialists
- careful development based on computer-aided rope dimensioning
- produced by the world's largest wire product manufacturer using state-of-the-art machinery
- due to the manufacturer's own wire drawing process, the raw material is already of unique quality

Rope technology basics - All about the strand

A strand consists of one or more layers of wires wound helically around a core (Fig. 1).

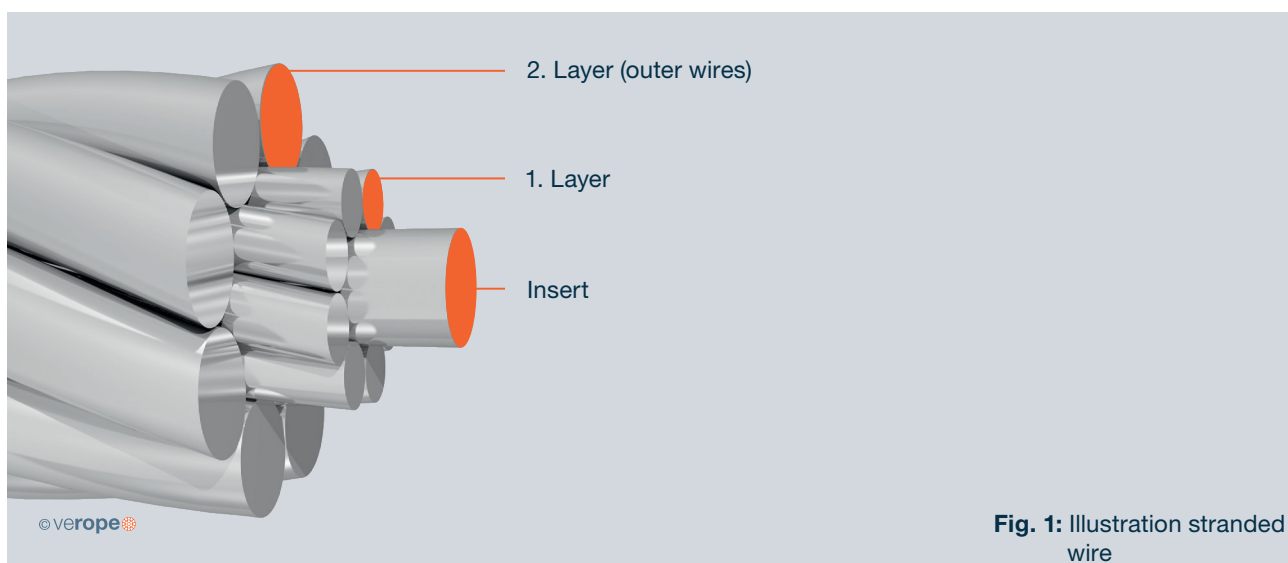

Fig. 1: Illustration stranded wire

Strand lay length

The lay length of a strand is the pitch of the helically laid wires, i.e. the length of the strand at which the wire runs completely around once. By changing the lay length, the contact ratios of neighboring wires, the elastic properties and the breaking forces of the strand can be changed.

Lay direction of the strand

A distinction is made between left-hand and right-hand lay strands. The lay direction of a strand is left-handed if its wires (moving away from the observer) are twisted counterclockwise (Fig. 2). The lay direction of a strand is clockwise when its wires (moving away from the observer) are twisted clockwise (Fig. 3). The lay direction of the strands is often indicated with the lower case letter s for the left-hand strand and the lower case letter z for the right-hand strand.

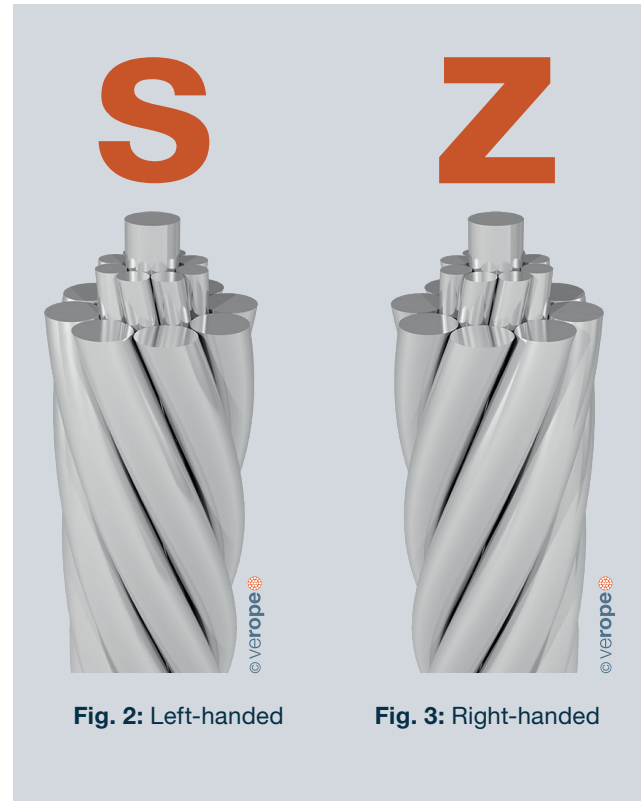

Strand diameter

The strand diameter is the diameter of all the outer wires enclosing the enveloping circle. The strand diameter is usually measured with micrometer screws and specified to an accuracy of 1/100 mm. (Fig. 4)

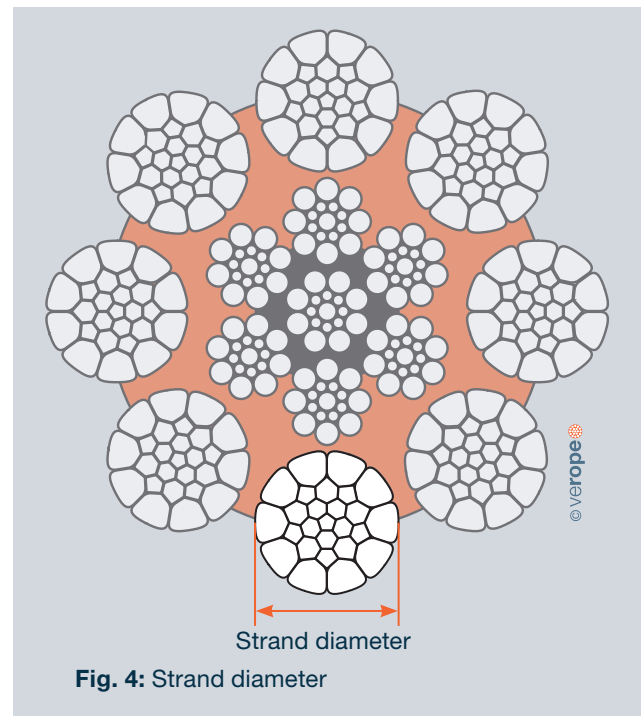



Abb. 5: Standard stranded wire



Abb. 6: Parallel impact strands

Strand construction

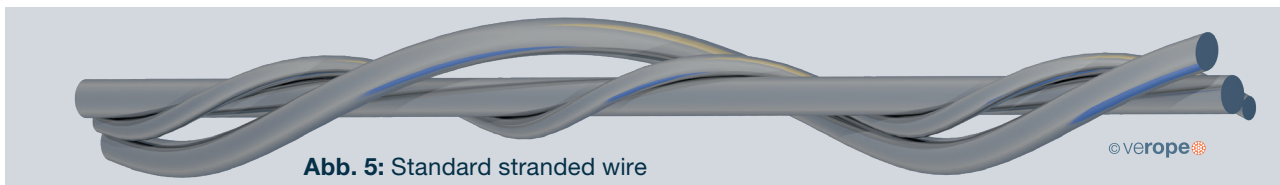
The construction of a strand is understood to be the formation law according to which the wires are arranged relative to each other. For example, all strands of the Seale type have the structure 1 - n - n (with n = 3, 4, 5, 6, 7, 8, 9 ...). In accordance with EN 12385-3, wire layers that are stranded parallel to each other in the same operation are connected in the designation by a minus sign. - . connected. The designation of a strand of type Seale 17 is therefore 1 - 8 - 8, the designation of a strand of type Seale 19 is 1 - 9 - 9.

The two- and three-layer standard strands have crossovers between the wires of the different wire layers (Fig. 5). Here, the wire layers are stranded in separate operations in the same direction (short line N) with the same stranding angle but different lay lengths.

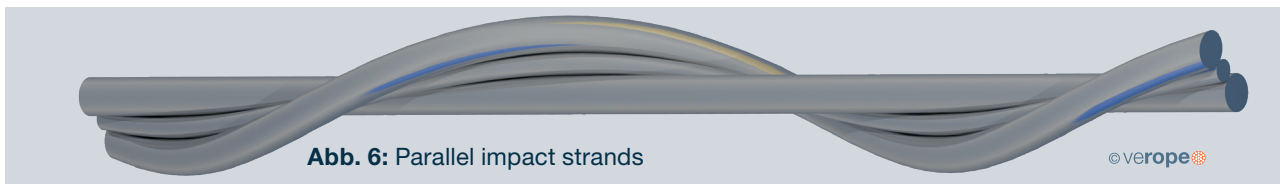
The so-called parallel lay strands (Seale, Filler, Warrington, Warrington-Seale) avoid crossovers and instead produce line contact of the wires (Fig. 6) by stranding all wire layers with different stranding angles but the same lay length.

The most important strand types are the single, double and triple layer standard strands (Fig. 5 and 7), as well as the parallel lay strands of the Seale, Filler, Warrington and Warrington-Seale types (Fig. 6 and 7).

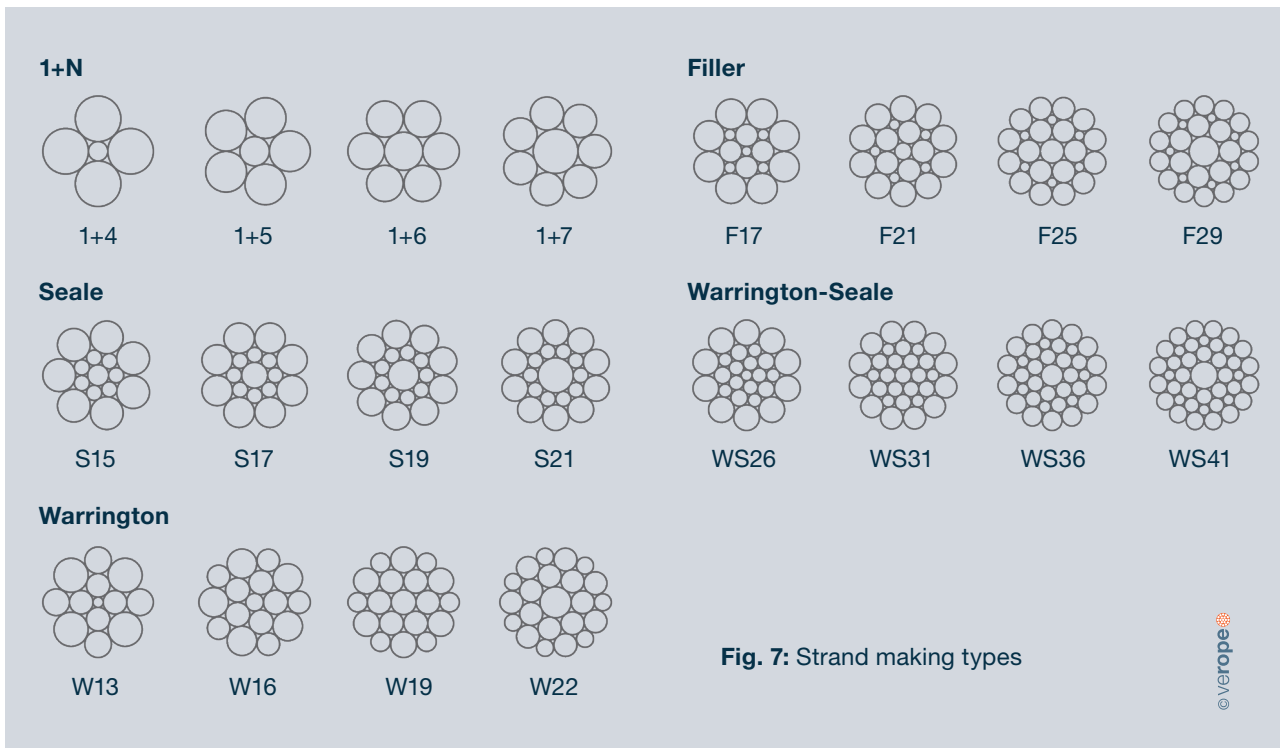

Fig. 7: Strand making types

Compacted round strands

Compacted round strands are first produced conventionally from torsion-free stranded round wires. They are then compressed to a smaller diameter either in the same or in a separate work step, for example with the help of

drawing dies or rollers, whereby the originally round wires are severely deformed on the compression tool and on the adjacent wires (Fig. 8).

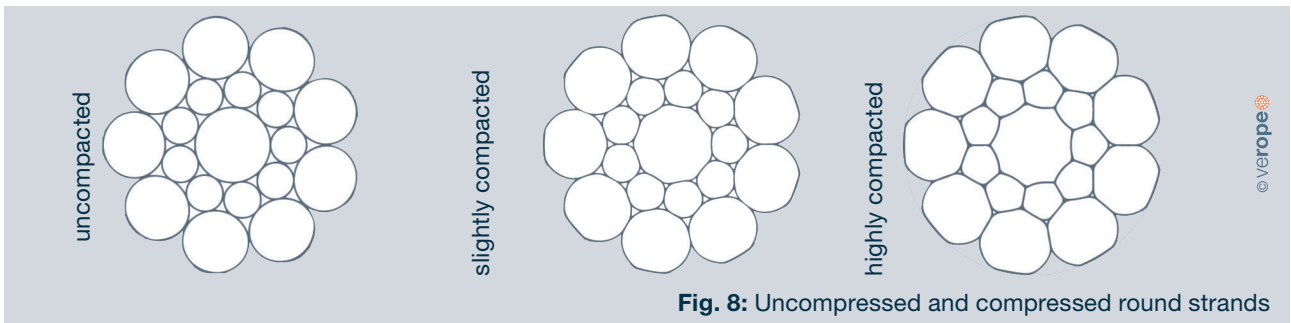

Fig. 8: Uncompressed and compressed round strands

Fill factor of the strand

The fill factor of a strand is the quotient of the metallic cross-section of the strand (simplified by definition as the sum of the individual wire cross-sections) in relation to the area of the smallest circle circumscribing the strand. The fill factor indicates what proportion of the space occupied by the strand in the rope is filled with steel. The fill factors of the most commonly used strands are approximately between 0.70 and 0.82. This means that the proportion of

steel in the strand volume is approximately 70% to 82%. The fill factors of the strands can be increased considerably through compaction. The fill factor of a strand generally increases as the number of wires increases. For example, a Seale 15 (1 - 7 - 7) strand has a fill factor of around 0.77 and a Seale 19 (1 - 9 - 9) strand has a fill factor of around 0.79.

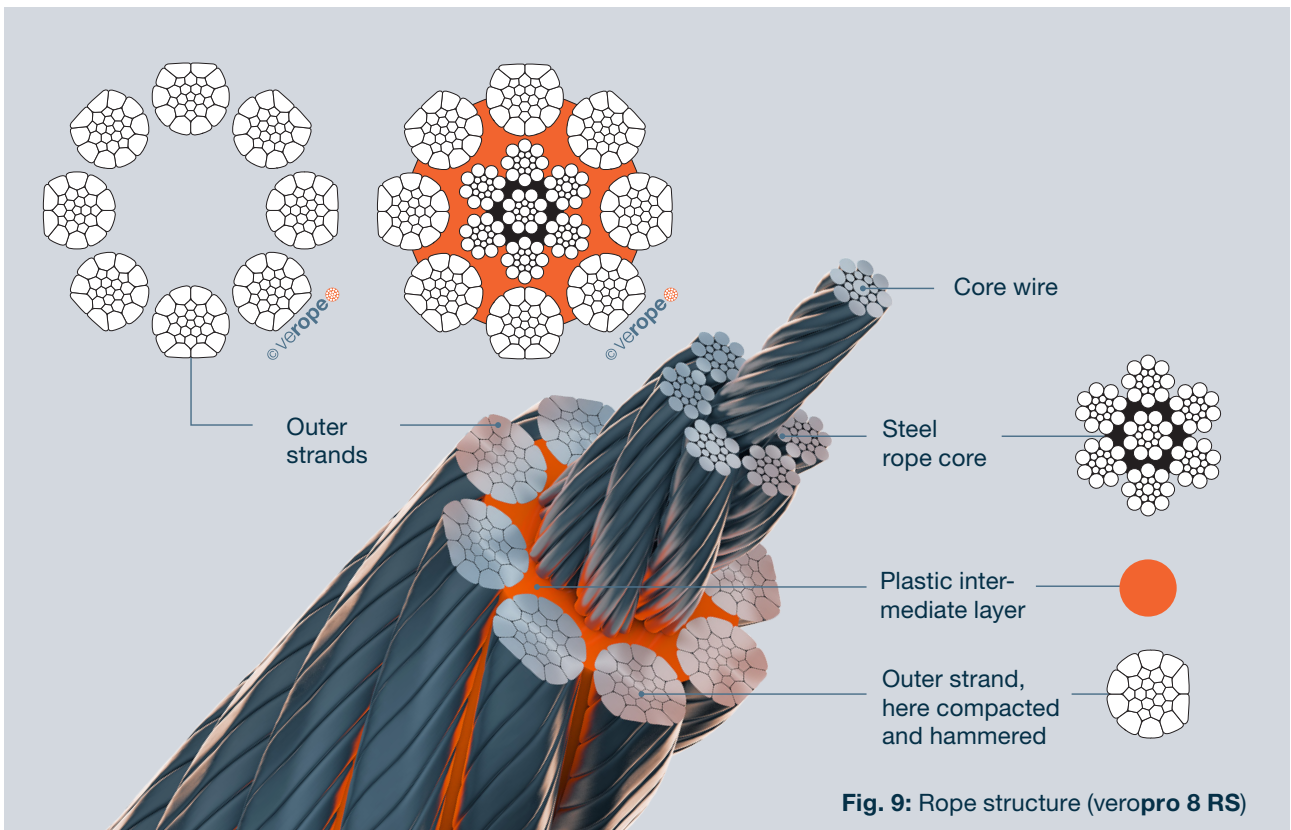

Fig. 9: Rope structure (veropro 8 RS)

Rope technology basics - All about the rope

Wire rope diameter

A distinction is made between a nominal rope diameter and an effectively measured rope diameter (actual rope diameter).

The nominal rope diameter, also known as the nominal rope diameter, is an agreed theoretical value for the diameter of the smallest circle circumscribing the outer strands.

The rope diameter, also known as the actual rope diameter or real rope diameter, is the diameter of the smallest circle circumscribing the outer strands actually measured on the wire rope.

The tolerance range for the actual rope diameter is specified in the tables of the respective national or international standards. According to EN 12385-4, it is 0 % to +5 %

(rope diameter for ≥ 8 mm). This means that when the wire rope is delivered, the actual rope diameter must not be smaller than the nominal diameter, but must also not exceed it by more than 5%. In the case of thin ropes, e.g. 3 mm to 7 mm, the tolerance field is often larger at the top. In the oil industry, which is strongly oriented towards American specifications, a tolerance range of -1% to +4% often applies. Of course, the actual rope diameter changes depending on the rope load. Therefore, in borderline cases, the actual rope diameter should be measured on a rope loaded with 5 % of the calculated breaking force. verope® produces ropes with standard tolerances of +2 % to +4 %; special rope diameter tolerances are manufactured on request

Measuring instruments and their correct use

To determine the exact diameter of the rope, you need a special measuring instrument. In principle, measurements should be taken on the vertices (outer circle of the rope sheath). Measuring in the hollows of the strands consid-

erably distorts the result. For ropes with an uneven number of outer strands, ensure that the measuring surfaces extend over several strands. (fig. 10).

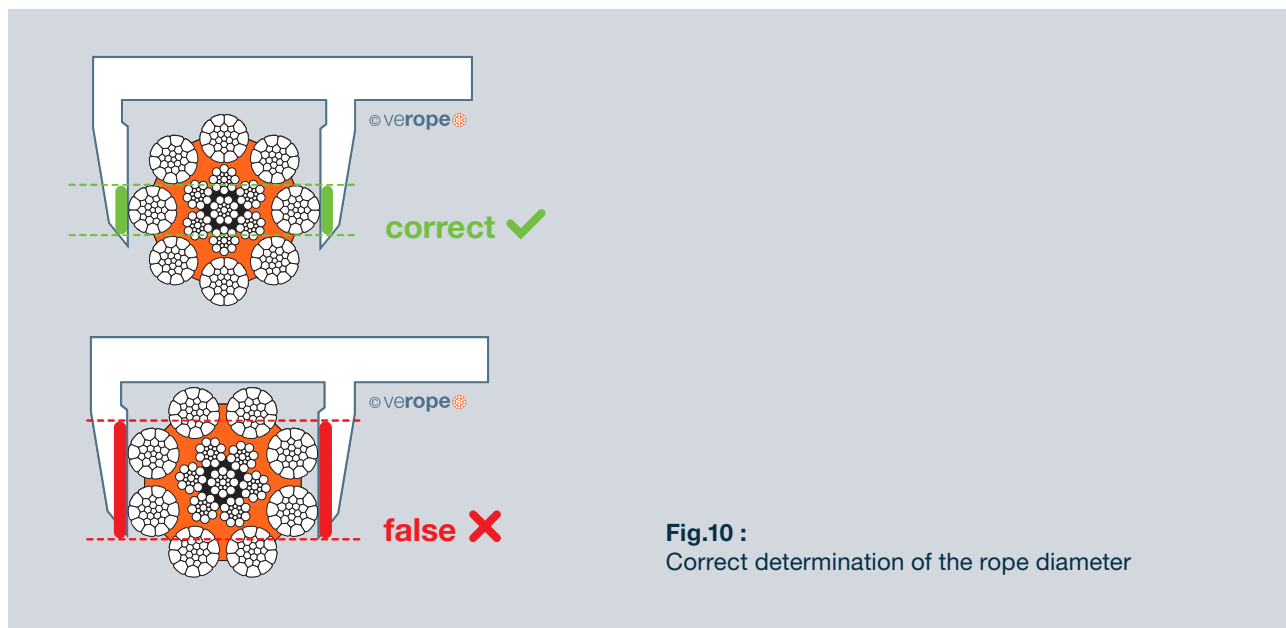
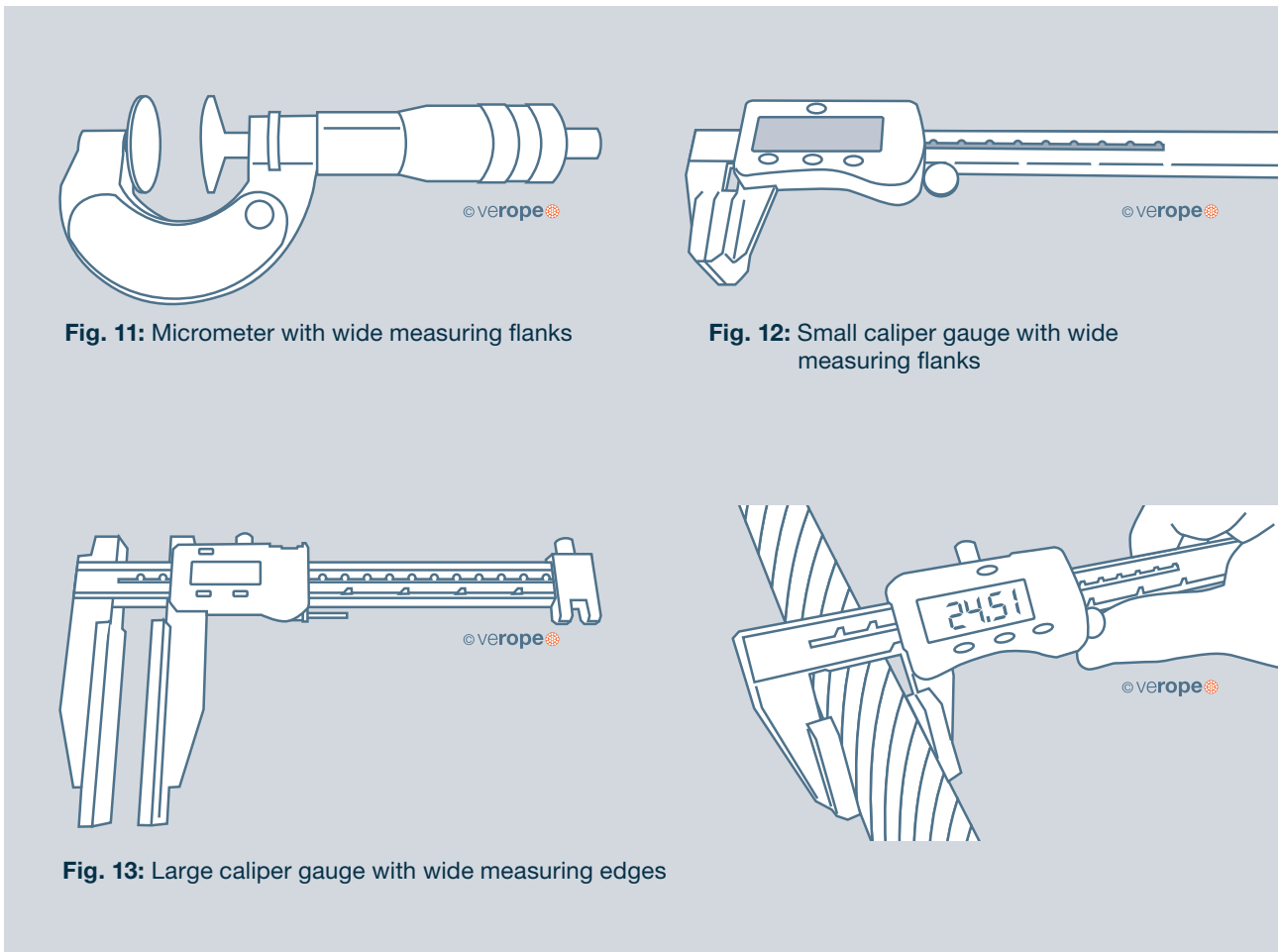

Fig.10 :
Correct determination of the rope diameter

Types of measuring equipment



Lay direction of the wire rope

A distinction is made between right-hand and left-hand lay wire ropes. The lay direction of a rope is left-handed if its strands (moving away from the observer) are rotated counterclockwise (Fig. 14). The lay direction of a rope is clockwise when its strands (moving away from the viewer) are rotated clockwise (Fig. 15). The lay direction of wire ropes is often indicated by the capital letter S for the left-hand rope and the capital letter Z for the right-hand rope. Right-hand ropes are also often designated as RH (for right hand) and left-hand ropes as LH (for left hand).



Wire rope construction

The construction of a wire rope refers to the formation law according to which the elements of the rope, i.e. its wires and strands, are arranged relative to each other. The designation for a fiber core is FC (Fibre Core), for an inde-

pendent steel wire rope core is IWRC (Independent Wire Rope Core). For example, all round strand ropes of the 6 x 19 Warrington type with a fiber core have the structure 6 x [1-6-(6-6)] - FC.

Fill factor of the wire rope

The fill factor of a wire rope is the quotient of the metallic cross-section of the rope (simplified by definition as the sum of the individual wire cross-sections) in relation to the cross-section of the smallest enveloping circle of the rope. The fill factor indicates what proportion of the space occupied by the wires and strands in the rope is filled with steel (Fig. 16).

Fig. 16: The fill factor of the wire rope is the ratio of the wire cross-sections (white areas) to the cross-sectional area of the smallest enveloping circle (white plus gray areas).

The fill factors of the most common ropes are approximately between 0.46 and 0.75. This means that the proportion of steel in the rope volume is approximately 46% to 75%. Wire ropes with a steel core have higher fill factors than ropes with a fiber core. For example, a 6 x 25 Filler - FC rope has a fill factor of 0.50, while a 6 x 25 Filler - IWRC rope has a fill factor of 0.58. The fill factors of wire ropes with fiber cores (FC) generally decrease as the number of outer strands increases. A rope of the 6 x 25 Filler - FC type has a fill factor of 0.50, a rope of the 8 x 25 Filler - FC type has a fill factor of only 0.45. The fill factors of ropes with a steel wire rope core (IWRC) generally increase as the number of outer strands increases. A rope of the type 6 x 25 Filler - IWRC has a fill factor of 0.58, a rope of the type 8 x 25 Filler - IWRC a fill factor of 0.59.

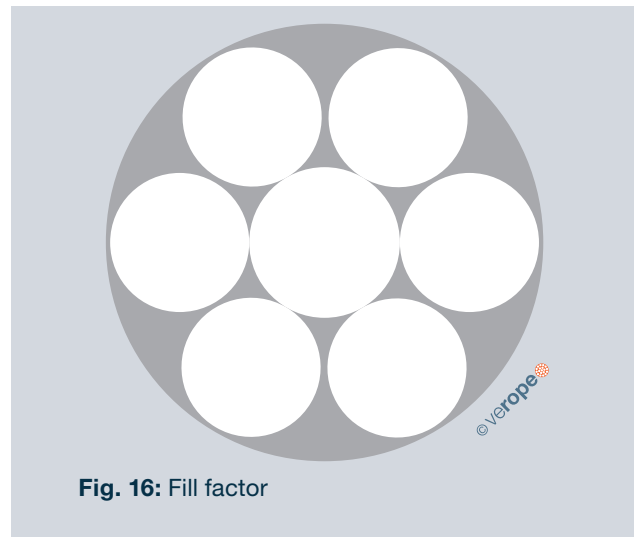

Fig. 16: Fill factor

Wire ropes made of compacted strands have higher fill factors than wire ropes made of non-compacted strands. The fill factor of wire ropes can be increased even further by hammering.

Type of lay of the wire rope

We distinguish between cross lay and regular lay. In cross lay ropes, the lay direction of the wires in the strands is opposite to the lay direction of the strands in the rope. We distinguish between left-hand cross lay (strand laid on the right, rope laid on the left, zS) (see Fig. 17) and right-hand cross lay (strand laid on the left, rope laid on the right, sZ) (see Fig. 18).

In regular lay ropes, the wires in the strands have the same lay direction as the strands in the rope. We distinguish between left-hand lay (left-hand lay strand, left-hand lay rope, sS) (Fig. 19) and right-hand lay (right-hand lay strand, right-hand lay rope, zZ) (Fig. 20).

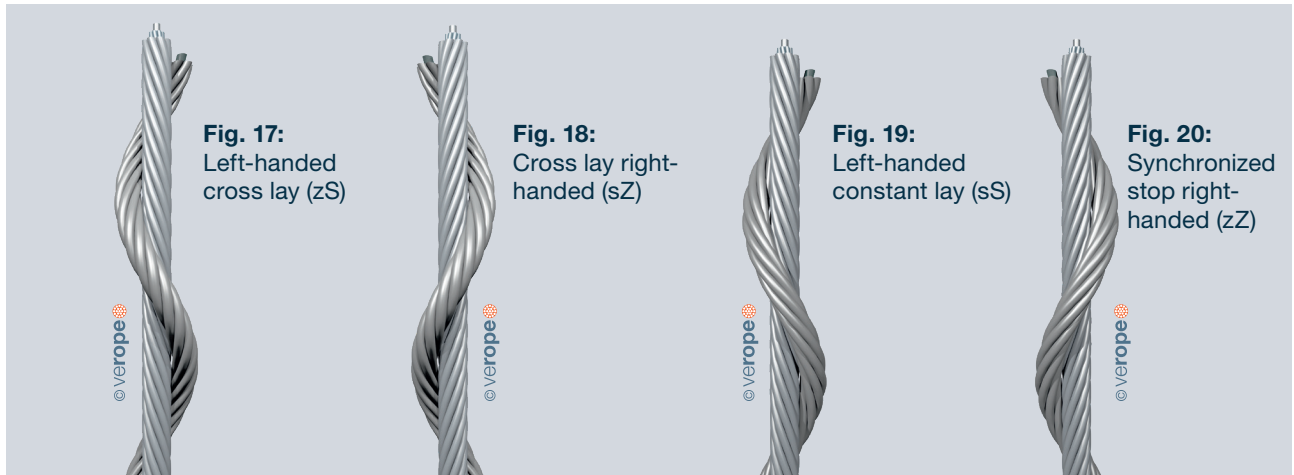

The advantages of cross lay ropes are:

- Better structural stability
- Higher number of discard wire breaks
- Easier detection of wire breaks

Low-tension wire ropes

During stranding and stranding, the originally straight wires are forced into a helix or double helix. As a result, the wires are under tension even in the unloaded wire rope. With the help of a so-called preforming head, the wires and strands can be plastically deformed during stranding or stranding to such an extent that they lie completely or almost completely unstressed (the roper says: dead) in the wire rope after elastic recovery. A non-stressed wire rope must be tied off very tightly to the left and right of the cutting point before it is cut, as otherwise the wire ends that become free will spring open.

Types of rope core

(Abbreviations according to EN 12385-2) Wire ropes usually have a fiber core (FC) or a steel core. The steel core can be a strand (WSC), a rope stranded independently, i.e. in a separate operation (IWRC) or a rope stranded in parallel with the outer strands in the same operation (PWRC (Parallel Wire Rope Core)). The steel core can also have a plastic coating (designation EPIWRC). Cores made of compacted strands bear the suffix (K). An independent steel wire rope core made of compacted strands therefore bears the designation IWRC (K), while a rope made of compacted strands stranded parallel to the outer strands in the same operation bears the designation PWRC (K).

The advantages of Lang lay ropes are:

- Better fit to the rope groove
- Higher wear resistance
- Longer service life with high dead loads
- Significantly better behavior with multi-layer winding

Rotation-resistant wire ropes

Under the effect of a tensile load, wire ropes with a free rope end rotate more or less strongly around their longitudinal axis.

Wire ropes with a steel wire rope core, which is laid in the opposite direction to the outer strands, as well as three- or four-strand cross lay ropes, exhibit significantly less rotation than wire ropes with a steel wire rope core laid in the same direction or wire ropes with a fiber core.

According to VDI guideline 2358, a wire rope is considered to have low rotation resistance if it rotates only slightly around its longitudinal axis under the effect of an unguided load and/or if it exerts only a small torque on the rope end connection when the rope ends are guided.

ISO 21669 and EN 12385-3 define a rope as rotation-resistant if it rotates around itself at least once and at most four times (between 360° and 1440°) over a length of 1000 x rope diameter and an axial load of 20% of its minimum breaking load.

Rotation-free wire ropes

According to VDI guideline 2358, a wire rope is rotation-free if it hardly rotates about its longitudinal axis under the effect of an unguided load and/or if it hardly exerts any torque on the rope end connection when the rope ends are guided.

ISO 21669 and EN 12385-3 define a rope as rotation-free if it rotates around itself no more than once (between -360° and 360°) over a length of $1000 \times$ rope diameter and an axial load of 20% of its minimum breaking load.

Wire rope lubricant

The wire rope lubricant has two main tasks: Firstly, it should protect the rope against corrosion and secondly, it should reduce the coefficient of friction between the rope elements and between the rope and sheave or drum. A reduction in the coefficient of friction reduces the required drive power and the wear on the rope, sheave and drum. We differentiate between wax-based lubricants and oil-based lubricants. While wax-based lubricants allow better handling, oil-based lubricants have the advantage that a torn lubricating film can close again automatically under the effect of gravity. The quality of the lubricant has a considerable influence on the service life of the rope (Fig. 21).

Relubrication

Wire ropes are always intensively lubricated during production. However, this lubrication must be renewed several times during the service life of the rope. Regular relubrication significantly increases the service life of the rope (Fig. 22). It must always be ensured that the relubricant is compatible with the basic lubrication. It is recommended to follow the maintenance instructions in ISO 4309.

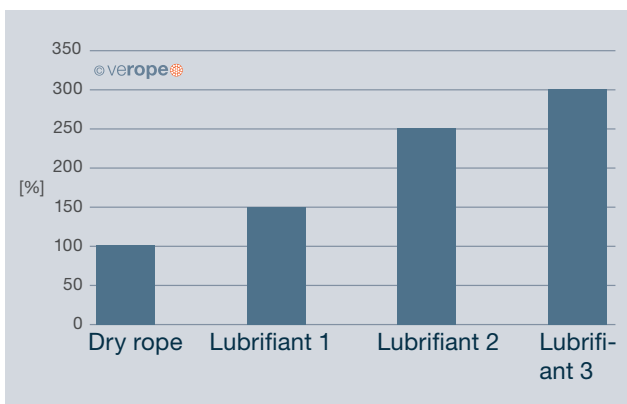

Fig. 21:
Influence of the lubricant on the service life of the rope

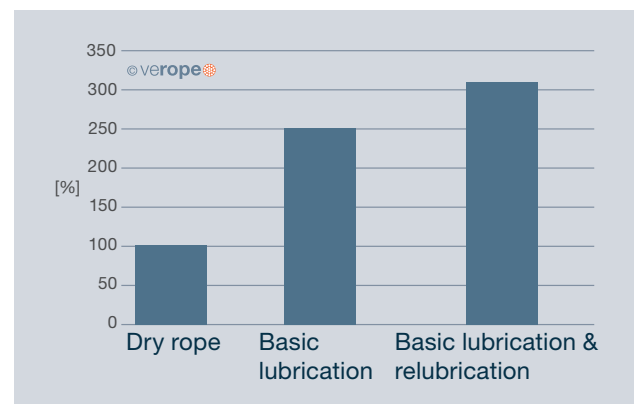

Fig. 22:
Influence of relubrication on rope service life

3.2 Rope end connections

Dimensional reference points for exact rope length determination

The rope length is very important for certain rope applications, e.g. holding and tensioning ropes. With the help of the following terminology, we would like to explain the important dimensional reference points for length determination and show some typical examples. This should help you to use the abbreviations explained in your order to avoid confusion when specifying lengths. In addition to the dimensional reference points, it is of course also important to specify the force under which the length is to apply. If no force is specified, it is assumed that the rope force $F = 0$ kN.

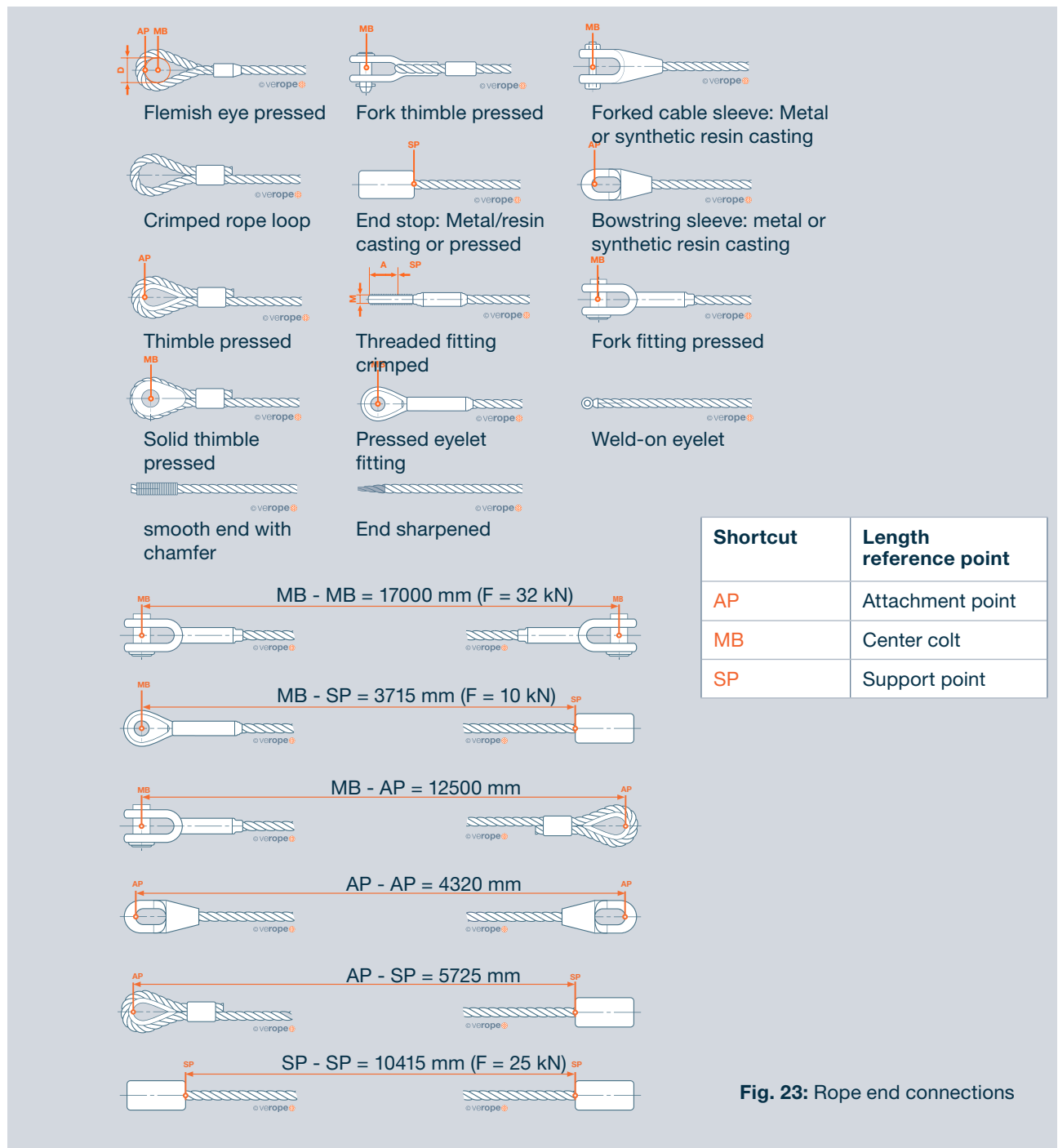

Fig. 23: Rope end connections

Remaining breaking force of the rope end

terminations Efficiency factor K_T of rope end terminations

The minimum breaking force of a rope specified in the data sheet is a „...specified value in kN, which must not be less than the breaking force measured in a prescribed breaking force test“ (source: DIN EN 12385-2, 3.10.10). It is particularly important for the crane designer to know what influence a selected rope end connection has on the

the selected rope end connection has on the transmissible breaking force of the rope-rope end connection system. The minimum test force to be achieved when testing a rope end connection in the tensile test is determined in relation to the minimum breaking force of the rope, taking into account the efficiency factor K_T .

$K_T = 0.9$ means that the test force to be achieved must be at least 90% of the minimum rope breaking force.

Unless otherwise specified, the following basic rules apply:

$K_T=1.0$ for grouted rope end terminations

$K_T=0.9$ for swaged rope end terminations

$K_T=0.8$ for wedge end clamps.

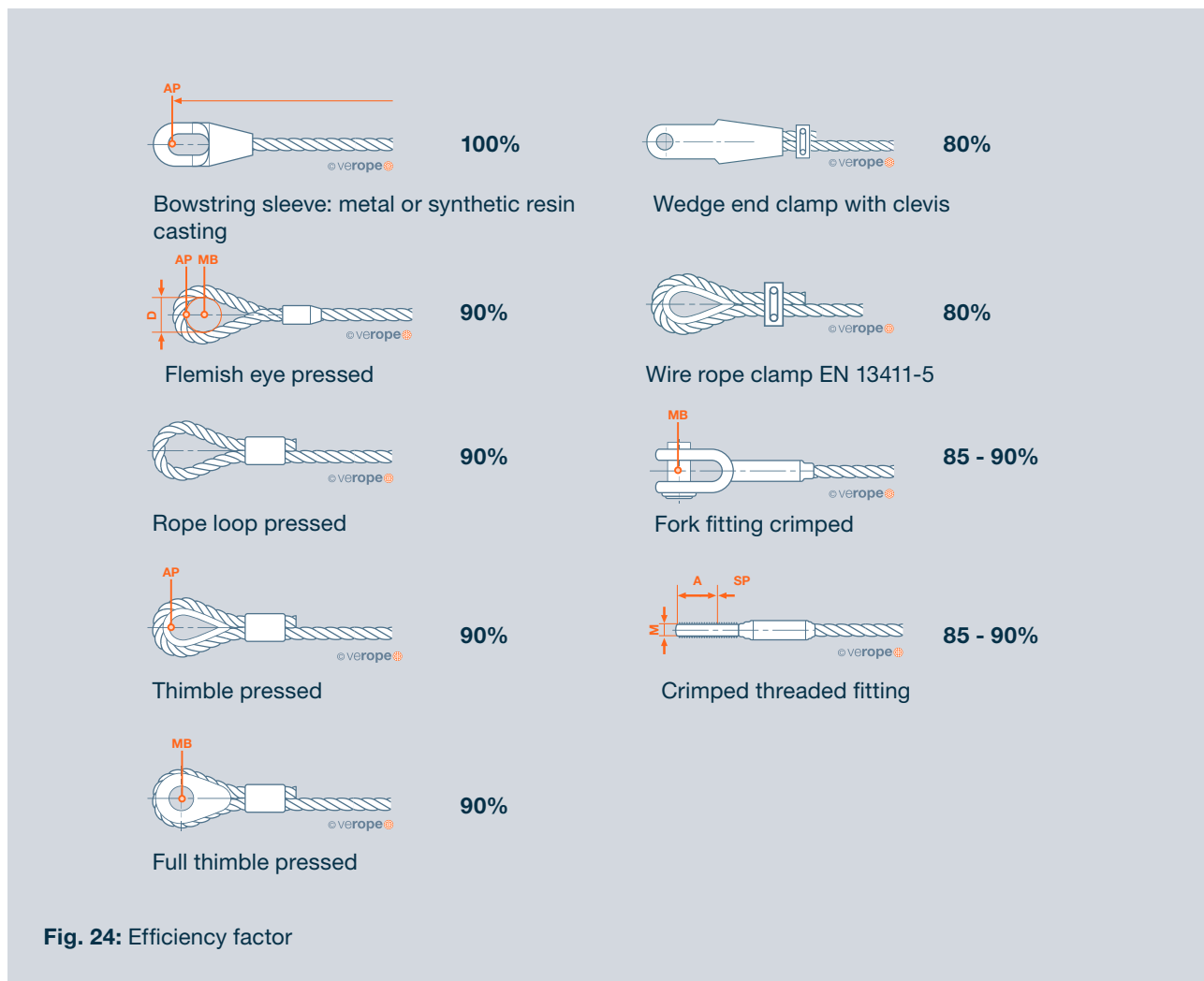

Requirements for ropes from the crane's point of view

- General

When selecting a rope, it is always necessary to carefully check which operating and therefore rope stress conditions dominate from the crane's point of view. These stress conditions differ significantly and justify the production of special ropes, i.e. solutions tailored to the application that can fulfill these dominant requirements in the best possible way.

Of course, there are ropes that already cover the essential requirements of their design class very well. From our pro-

duct range, the ropes

veropro 8 for non-rotation-resistant applications and verotop for rotation-resistant applications. Of course, there are also the real „specialists“, ropes with special strengths, which you can rely on for dominant requirements, e.g. wear resistance, lateral pressure stability or fatigue strength.

We will be happy to assist you in selecting the best possible rope for your application.

3.3 Guide to rope selection

The right rope selection for your rope application - details

When selecting a rope, two points of view must be reconciled: the rope selection from the point of view of the application and from the point of view of the rope. There is no such thing as a „universal rope“ that is equally suitable for all applications. This is why there is a wide range of different rope constructions to best meet the various requirements of the applications. With the following explanations, we would like to provide you with some practical information to help you select the right rope for your application. The verope® team will of course be happy to answer any questions you may have.

Rope selection from an application perspective

The main task of a crane is to lift and move loads, for which a hoist rope is required. In addition to this crucial „lifting function“, there are many other functions.

- Adjustment ropes to bring the boom into the correct position
- Trolley ropes to move the load on tower cranes/container cranes
- Holding ropes to hold the boom or other crane parts
- Assembly ropes to erect or dismantle the crane
- ... and many more

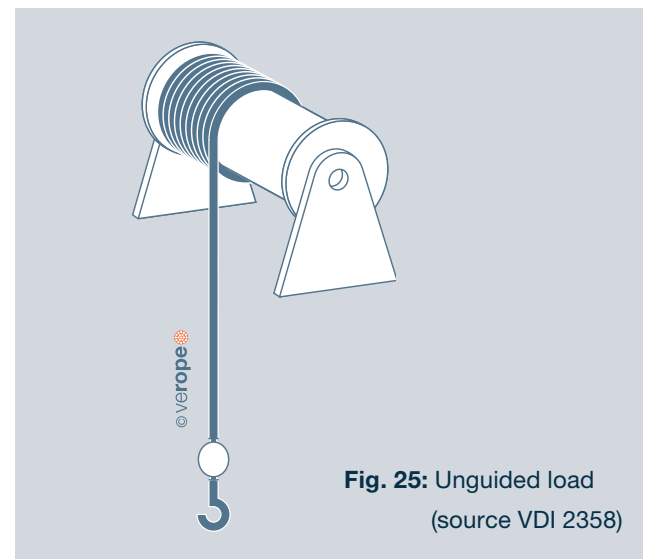

Lifting function

There are two main categories into which crane ropes can be divided based on their application:

- Rotation-resistant ropes, often referred to as rotation-free ropes or strand spiral ropes in common parlance
- Non-rotation-resistant ropes

Only rotation-resistant wire ropes give the load the necessary stability so that the load does not rotate or only rotates very slightly. In addition, rotation-resistant wire ropes attached to the crane structure only generate very low torques at the attachment point. The low-rotation verope® special wire ropes therefore guarantee safe lifting of the load and thus safe crane operation.

The wire ropes designated as „rotation-resistant“ according to the standard differ significantly in their design and therefore in their characteristics with regard to freedom from rotation. A classification is used to show these differences in freedom from rotation. For example, EN 12385-4 designates the rope class „35x7“, which describes rotation-resistant ropes with 3 strand layers, and the rope class „18x7“, which describes rotation-resistant ropes with 2 strand layers. The freedom of rotation of both rope classes, but also the rope manufacturing costs and therefore the prices for the customer, are very different.

A further example to illustrate the different freedom of rotation is the classification according to ASTM A 1023, which divides rotation-resistant ropes into 3 categories. The most common categories for lifting functions are „Category 1“ and „Category 2“:

Category 1: rotation-resistant ropes with at least 15 outer strands offer the best properties in terms of freedom from rotation.

Category 2: rotation-resistant ropes with 10 or more outer strands.

With regard to the comparability of both standards, it can generally be said that ropes of rope class „35x7“ have a comparable freedom of rotation resulting from the rope construction as ropes of category 1 according to ASTM A1023. Similarly, ropes of rope class „18x7“ can be compared with those of category 2 according to ASTM A1023. For very demanding lifting functions, only ropes of rope class „35x7“ or „Category 1“ should be used.

Please note: Ropes of rope class „35x7“/ category 1 must always be replaced by equivalent ropes, never by ropes of rope class „18x7“/ category 2! Low-rotation ropes of „Category 2“ or rope class „18x7“, on the other hand, can also be replaced with ropes of „Category 1“ or rope class „35x7“, which are of higher quality in terms of freedom from rotation, from a technical point of view.

NOTE:

In addition to the rotation-resistant ropes that are manufactured in accordance with national or international standards, there are many other rotation-resistant rope constructions that not only meet standard requirements, but also significantly higher requirements in terms of freedom of rotation. These ropes are truly special ropes, developed for the highest requirements in terms of freedom of rotation, e.g. for the highest hook heights of the most modern cranes. In order to provide the user with a general guideline for classifying such special wire ropes, the standard designations explained above are also used for these in addition to the manufacturer-specific product names, even though the performance is higher.

IMPORTANT:

If rotation-resistant ropes are required, they must not be replaced by non-rotation-resistant ropes.

Use of swivels for hoist ropes

Under certain circumstances, twist can occur in the rope drive. The use of a swivel can be very helpful in reducing this twist, e.g. if the deflection angle between the drum and the first sheave or between the sheaves exceeds the recommended values. In the case of multiple reeving, however, the twist catcher cannot compensate for the twist to the same extent in all rope strands. In this case, the twist is preferably reduced in the first rope strands after the twist catcher. The swivel reduces the risk of twisting the hook block, but also of rope damage such as cork-screwing or cage formation, which can lead to the rope dropping.

Please note that only ropes of „Category 1“ according to ASTM A1023 or rope class „35×7“ according to EN 12385-4 may be used both with and without a swivel. For all other low-rotation rope constructions, a swivel must not be used.

Further information on the use of a swivel can be found in EN 12385-3 and ISO 21669.

verope® range of rotation-resistant ropes

The verope® product range of rotation-resistant ropes consists of high-performance special ropes:

verotop P
 verotop XP
 verotop
 verotop S
 verotop S+
 verotop E

and the 4-strand low-rotation verope® rope construction:

vero 4

With the exception of the 4-strand vero 4 rope, all our ropes are category 1 rotation-resistant high-performance ropes that offer maximum freedom from rotation. All „-top“ ropes from verope® can therefore be used with or without a swivel. vero 4 is a very robust rope that has been designed for the toughest working conditions and dynamic loads, but not for freedom from rotation, only for low rotation.

Although vero 4 is a low-rotation rope, it must not be used with a twist arrester without being tested by an expert or after consultation with verope®.

The basic rule is that rotation-resistant ropes must be used for the „lifting function“. There are also exceptions here under the following conditions:

1. for „lifting function“ with a guided load, a non-rotation-resistant rope can also be used, as the load rotation is prevented by the frame that guides the load.
2. non-rotation-resistant ropes can also be used for the „lifting function“ with an unguided load if the same rope construction is used as a pair consisting of a right-hand and left-hand rope. This configuration also offers torsional stability, i.e. the load has little or no tendency to twist, as the torque generated under load is the same but acts in the opposite direction, resulting in a torque equilibrium.

IMPORTANT:

In terms of bending fatigue performance, rotation-resistant ropes are clearly inferior to non-rotation-resistant ropes. Non-rotation-resistant ropes should therefore only be replaced with rotation-resistant ropes with extreme caution. This must be clarified with a rope expert.

Other crane rope applications

Non-rotation-resistant ropes generally achieve higher bending cycles than rotation-resistant or rotation-free ropes. However, they exert a torque on the rope end connection under load. For this reason, non-rotation-resistant wire ropes can only be used if the rope ends are permanently secured against rotation.

Non-rotation-resistant ropes are always the right choice of rope when the „freedom from rotation“ property, which only rotation-resistant ropes can offer, is not required. This is the case for many rope applications, such as adjusting ropes, trolley ropes, holding ropes or assembly ropes.

NOTE:

When coupling non-rotation-free ropes, e.g. retaining ropes or grab closing ropes, only identical ropes of the same design, i.e. the same diameter, lay type and flexibility, may be used. Coupling different lay directions would untwist the ropes and thus destroy them.

Use of cross and constant lay ropes

The selection of the type of lay must take into account the specific use of the rope, the rope construction, crane components and the expected service life of the rope as well as the main wear factors. The aim of rope selection is a long rope service life combined with safety, i.e. the safe operating condition of the rope can be reliably recognized at any time by the operator in the specific application, ta-

king into account the rope-specific discard criteria. It is therefore not possible or sensible to make a general statement on the use of cross or constant lay ropes without knowing the specific individual case. If you have any questions or uncertainties, please contact verope® AG.

Cross lay ropes

Cross lay ropes are widely used, which is why they are presumably also considered to be universally applicable. Cross lay ropes are very structurally stable due to the counter-rotating stranding of the wires and strands, which makes them more resistant to external twisting. The rope torque is lower than that of regular lay ropes. Cross lay ropes also offer good wear resistance. Due to the design, the externally visible wire breaks occur earlier than with regular lay ropes due to the higher pressure between the wire and the rope groove and the greater wire bending in the strand, which makes it easier to detect them in order to assess the rope condition with regard to discard maturity. Nonetheless, regular lay ropes are not universal ropes for all applications under the above-mentioned rope selection objectives.

Lang lay ropes

Lang lay ropes are not only more demanding to manufacture, but also to use, starting with installation. This is due to the fact that the wires and strands are stranded in the same direction, which increases the rope torque and makes Lang lay ropes much more sensitive to any kind of external twisting.

Lang lay ropes achieve high breaking bending cycles due to the geometrically more favorable contact ratios between the wire and the rope groove, which leads to a reduction in pressure at the contact points. This reduction in pressure is beneficial for the service life of the crane components and the rope itself. It should also be noted, however, that the development of externally visible wire breaks is slower than with cross lay ropes. It can therefore be more difficult to detect discard maturity due to externally visible wire breaks. As a result, the number of discard wire breaks

in regular lay ropes is significantly lower than in regular lay ropes with an identical rope structure. This means that Lang lay ropes are not universal ropes for all applications with the above-mentioned rope selection objectives.

NOTE:

As described in the section „Lang lay ropes“, their use can lead to increased wire breaks inside the rope without these being visible from the outside. This is particularly the case when using rotation-resistant ropes in constant lay under pure alternating bending stress and when running over plastic sheaves. This should be clarified with a rope expert or verope® AG.

Crane components and crane geometry

In addition to the rope itself, crane components and crane geometry are important criteria for the correct rope selection. The drum system used and the deflection angles selected by the crane geometry must be emphasized. While single-layer wound drums subject the rope not only to tensile load but also to bending and lateral deflection and thus twisting, mechanical wear and transverse compressive stresses between the contacting rope strands dominate in multi-layer winding.

The deflection angle selected by the crane geometry is an important parameter for reliable rope winding and the degree of rope wear. A maximum deflection angle of 1.5° is recommended for multi-layer winding, while single-layer drum systems can work with higher deflection angles, e.g. up to 4°.

The correct rope selection must therefore be adapted to these operating and wear conditions.

The following basic rules for selecting the type of rope lay for ropes wound on drums have proven their worth and are therefore also recommended by us:

- Single-layer wound drum = cross lay rope
- Multi-layer wound drum = Lang lay rope

Sur les tambours à une couche, le câble à torsion croisée présente des avantages évidents, car il peut mieux compenser les angles de déviation généralement plus importants. La détection plus facile des ruptures de fils visibles

In the case of single-layer drums, the lay rope has clear advantages as it can better compensate for the usually larger deflection angles. The easier detection of externally visible wire breaks is also an important argument in favor of the use of lay ropes on single-layer drums, where heavy mechanical rope wear, which also leads to wire breaks, is not or not significantly present. In the case of multi-layer winding, it is not the alternating bending fatigue strength of the rope but its resistance to mechanical impact that is decisive for the service life of the rope. Cross lay ropes are less suitable for multi-layer spooling because wires of neighboring rope strands can get caught in each other. This leads to high mechanical wear. The contact between the rope strands during the winding process is also clearly „audible“.

The result is premature wire breakage. Lang lay ropes have therefore successfully established themselves for multi-layer winding, as no interlocking of adjacent rope strands in contact is possible, which significantly increases the service life of the rope.

By using ropes with compacted outer strands or hammered rope constructions, the rope service life can be further increased due to the very smooth surface and high abrasion resistance.

The above explanations have proven themselves in practice.

Deviations requested by the customer on a case-by-case basis must therefore always be thoroughly checked with regard to the specific rope application conditions:

- specific rope application conditions
- the selected rope construction
- as well as the customer's rope monitoring with regard to discard maturity

before a deviating decision can be made.

3.4 Technical data

Breaking forces and rope weights can be found in the valid „verope® general catalog“.

For further technical information, please request the technical data sheet for the verope® special wire rope you are using by sending an e-mail to info@verope.com. More general information can also be found in ISO 4309.

3.5 Reference to catalogs or data sheets



You can download the brochures here
marketing@verope.com | www.verope.com

WORLD OF VEROPE® BROSCHÜREN

TECHNISCHE BROSCHÜRE →
Leitfaden mit zahlreichen Tabellen und Grafiken mit Hintergrundinformationen zum Aufbau und Umgang mit Spezialdrahtseilen.

HANDLING BROSCHÜRE ←
Hilfsmaterial mit wichtigen Hinweisen und Erklärungen, die unsere Kunden bei der korrekten und sicheren Seilhandhabung unterstützen.

GESAMT KATALOG →
Alle verope® Spezialdrahtseile in einem Gesamtkatalog zusammengefasst und nach Anwendungen sortiert.

IMAGE BROSCHÜRE GROUP ←
Die verope® Group mit ihren weltweiten Standorten stellt sich vor.

IMAGE BROSCHÜRE KV →
Weltweiter Technologieführer: Kiswire verope® Research & Development Center für Forschung und Entwicklung.

Bestellen Sie hier Ihre Broschüre:
marketing@verope.com | www.verope.com

SCHWERINDUSTRIE →
Diese Segmentbroschüre hilft Ihnen, das perfekte Seil für Ihre Anwendung auszuwählen.

BAUINDUSTRIE ←
Diese Segmentbroschüre hilft Ihnen, das perfekte Seil für Ihre Anwendung auszuwählen.

HAFENINDUSTRIE →
Diese Segmentbroschüre hilft Ihnen, das perfekte Seil für Ihre Anwendung auszuwählen.

BORDKRANE ←
Diese Segmentbroschüre hilft Ihnen, das perfekte Seil für Ihre Anwendung auszuwählen.

OFFSHOREINDUSTRIE →
Diese Segmentbroschüre hilft Ihnen, das perfekte Seil für Ihre Anwendung auszuwählen.

Fig. 26 : Brochures

3.6 General information

Important information

Incorrect selection and use of wire ropes can be dangerous.

Protect yourself and others!

Rope failure can cause serious property damage, injury or death!

With the following information, we would like to draw your attention to some essential points for the correct selection, operation and monitoring of wire ropes. In addition to technical literature on wire ropes and national and international standards, the verope® team will be happy to assist you with any questions you may have about wire ropes. Please contact us!

- Wire ropes must be properly transported, stored, installed and maintained. Please refer to the relevant literature on these topics.
- Wire ropes must be checked for wear or damage before each use. This also applies to their end connections. Never use worn or damaged ropes or end connections!
- Wire ropes must not be overloaded or subjected to shock loads!
- The rope behavior can change significantly when exposed to very high or very low temperatures. Please discuss this with our specialists.
- End connections fitted by verope® must not be modified by the customer, e.g. by machining.
- Our products are constantly undergoing further development. The technical data may change as a result. The latest data on our website is authoritative.
- The cross-sectional images in the catalog show a typical rope diameter. Ropes with smaller and larger diameters may have a different cross-section.
- Wire ropes and their end connections are not fatigue-resistant and must therefore be inspected regularly to ensure that they are in a safe operating condition. Wire ropes and their end connections must be discarded before reaching an unsafe condition. Please observe the applicable international or national standards (e.g. ISO 4309, EN 12385 and EN 13411) and the technical literature for expert inspection and correct determination of the discard state of wire ropes and their terminations.

4 PACKAGING, TRANSPORT, HANDLING AND STORAGE

4.1 Product labeling

CAUTION:

Incorrect handling and installation procedures can have serious consequences. Personal injury and damage to property can occur! The rope should be handled and stored in accordance with the usual instructions and under the supervision of a competent person.

- With regard to product labeling, please refer to the relevant contractual rope data sheet, label (or description), delivery bill and certificate.
- Missing or incorrect product labeling as well as a discrepancy between the certificates and the specifications of the order can lead to errors and incorrect installation!
- Make sure that the labeling on the rope or packaging corresponds to the corresponding certificate and delivery bill. If they do not, the rope or reel must be marked immediately in accordance with the delivery bill.
- Make sure that the correct rope has been delivered. The delivery bill, certificate and labeling, rope diameter, end connection, lay direction, rope structure, minimum breaking strength, galvanization and rope length must match.
- Keep the certificate in a safe place so that you can always identify the rope.
- Check the wire rope for damage immediately after delivery:
 - Transport damage to packaging and reel
 - Top layer of rope for damage such as broken wires, untwisting, kinking, etc.
- Note any damage on the delivery documents, do not use the wire rope.
- Keep the supplied declaration of conformity in a safe place for traceability purposes.

In the event of deviations or uncertainties:

Contact your distributor or verope® AG directly.

If you have any questions about the system, contact the designer/manufacturer of the machine or hoist.

4.2 Storage, handling & assembly

Always wear personal protective equipment and observe local regulations and risks during all of the following activities.



Use hearing protection



Use eye protection



Use foot protection



Use hand protection



Use protective clothing



Use head protection



Use safety vest



Use respiratory protection

General instructions

Unloading, stowing and transporting reels

Handling wire rope reels requires a certain degree of caution. The reel should therefore either be unloaded from the loading area using an industrial truck, whereby the reel is lifted using a sufficiently dimensioned shaft as an attachment point for the fork tines, or using the overhead crane as described in the picture below. The coiled rope should

always be moved as described below. Reels that are carelessly knocked over with the forklift can damage both the reel and the rope, so this is not advisable.

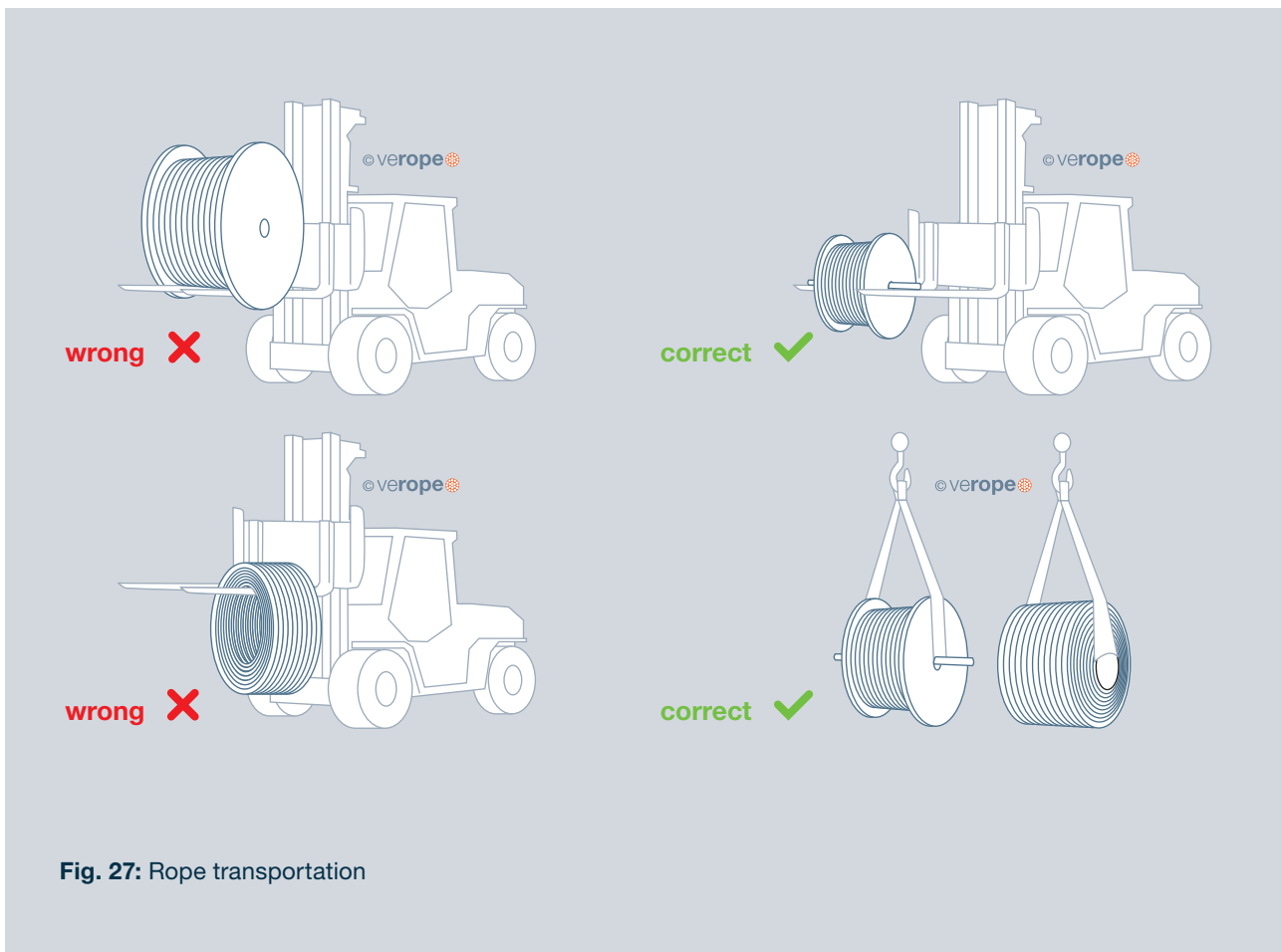

Correct storage of wire rope reels

After unloading, the reel must be stored correctly. It is important that the reel is always underlaid with a pallet to protect it from ground moisture. In addition, it should be stored in a covered area where the rope is protected from the weather. In any case, the reel must be protected from

rain and direct sunlight. Even if the measures described are only used for a short period of time.

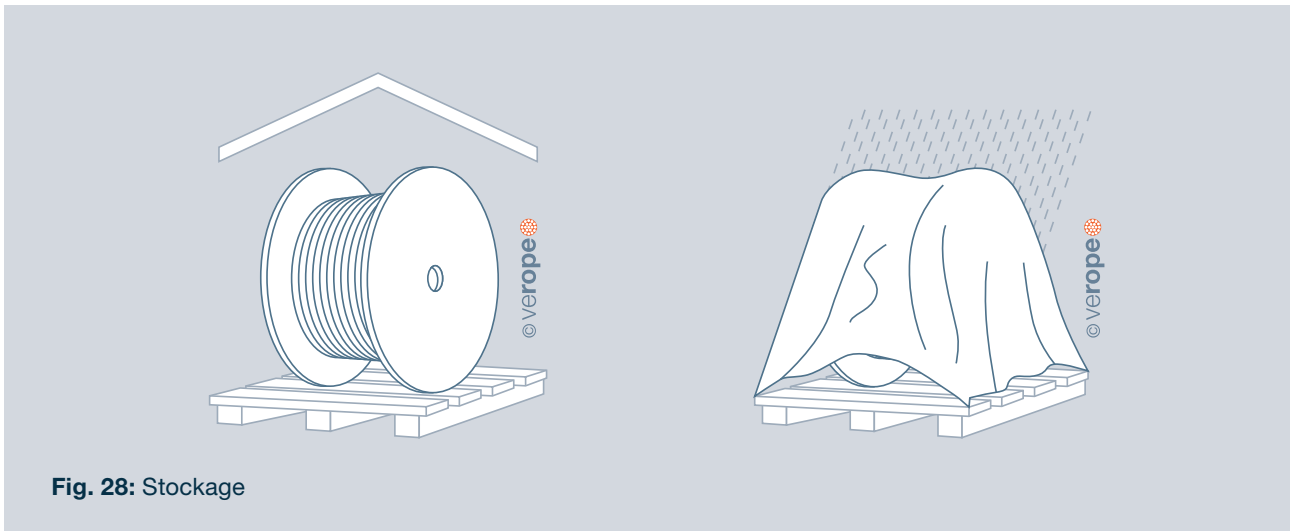

Handling the special wire rope during unwinding and rewinding processes

Suitable devices are required to spool the defined rope length onto a drum or to bring the rope into the system.

For example, turntables or winding stands (as shown in the picture) make it possible to install a rope.

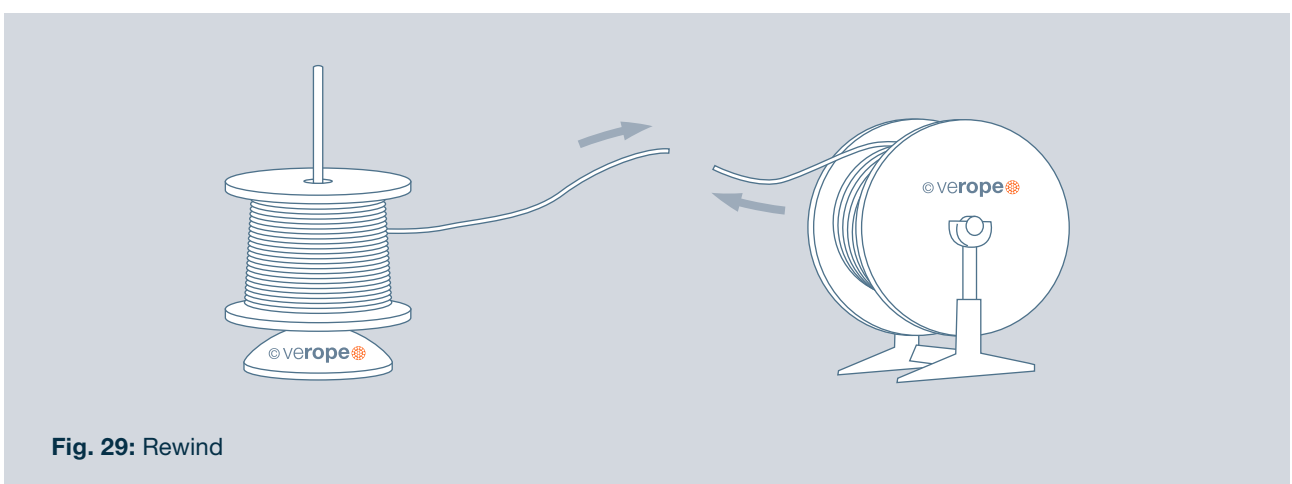

!! Take care when rewinding ropes due to protruding rope elements or trapping hands !!

For ropes that are spooled onto drums, it is also important that the correct spooling direction is maintained and that the rope is installed with pre-tension. If the rope is wound onto the drum from above, the rope must also run off the top of the reel. Crossing these directions has negative ef-

fects that can render the rope unusable. Pre-tensioning the rope to be installed serves to ensure rope safety and a clean spooling pattern on the drum. This pre-tensioning is mandatory, as the rope can be destroyed if it is loosely coiled and working under load.

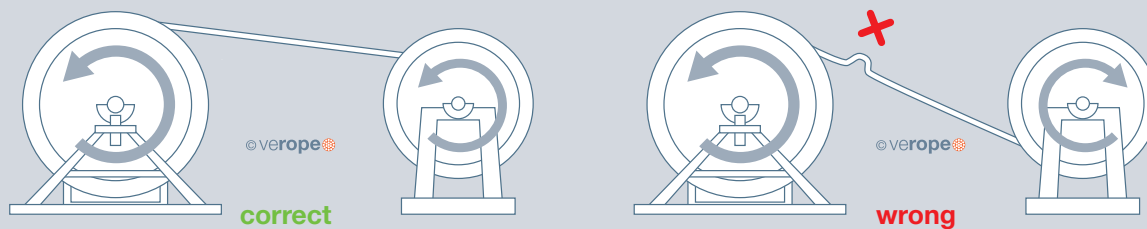

Fig. 30: Rewinding correct / wrong

According to the standard, a preload of at least 2.5 % to 5 % of the minimum breaking force should be applied. Often these values cannot be achieved with the available devices, in which case the motto „the more the better“ must

be applied. The following illustration shows the correct winding direction and a winding process in which the reel is braked.

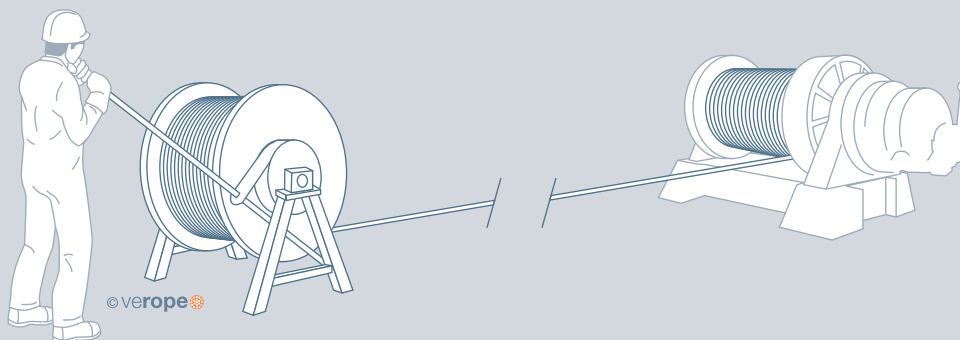

Fig. 31: Brake reels



!! Be careful when braking, hands may become trapped or slip off !!

The following pictures show the general procedures for removing or not removing the rope from the reel:

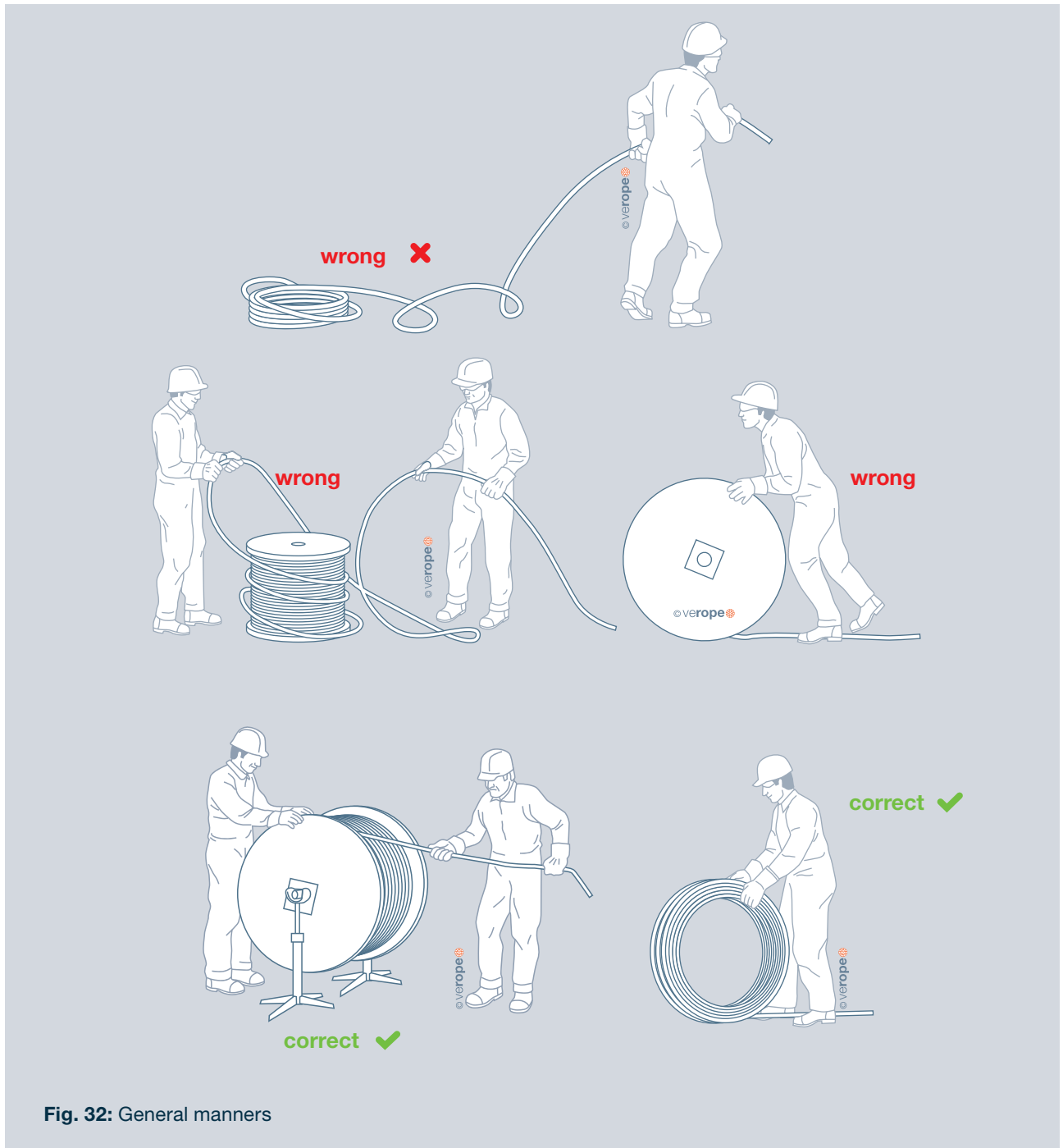

Fig. 32: General manners



!! Be careful when handling ropes, possible entrapment !!

How is a rope cut correctly?

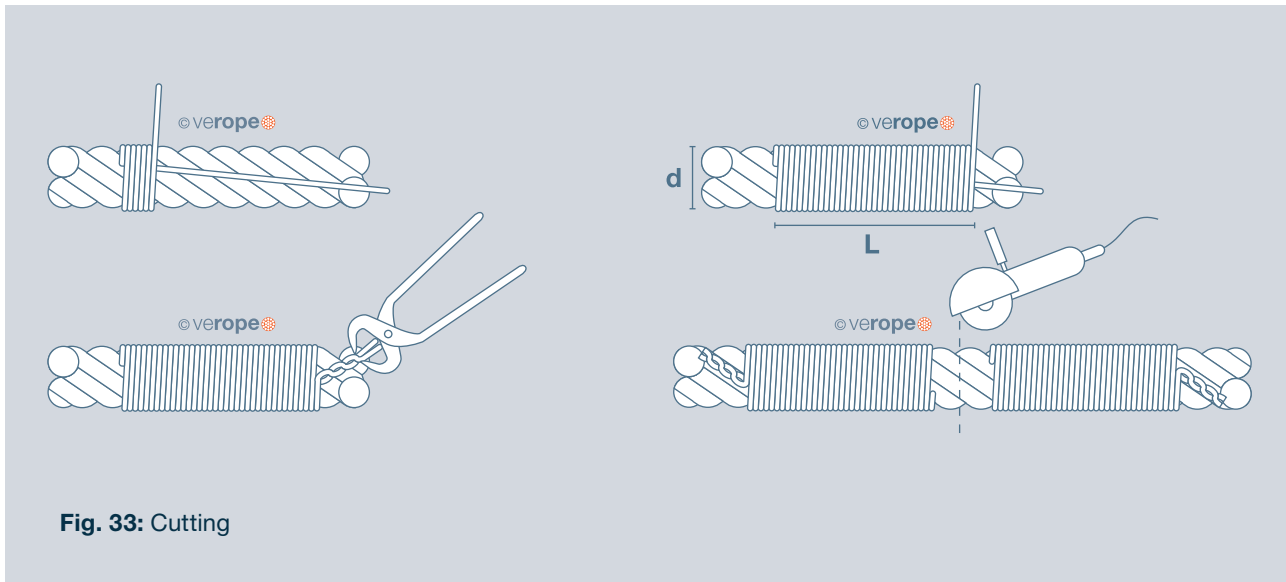

Fig. 33: Cutting



!! Be careful when cutting ropes, cuts and puncture injuries or jamming are possible !!



Naturally, the strands in a rope must follow a helix shape. This sometimes creates high tension in the individual rope elements. Due to these influences, ropes must be secured against uncontrolled unraveling. This is usually ensured by welding the ends or by attaching a suitable end connection. If you now want to shorten the rope to its original length, you must fix the rope to the right and left of the desired cutting point in accordance with EN 12385-2. rope in accordance with EN 12385-2. The pictures below

show the use of binding with stranded wire to secure the preformed rope against untwisting. The length of the binding is defined as follows:

$$L = 2 \times \text{nominal rope diameter } d.$$

For ropes that are not low tension, 2 fixed bindings must be placed on each side of the cut.

5. ASSEMBLY

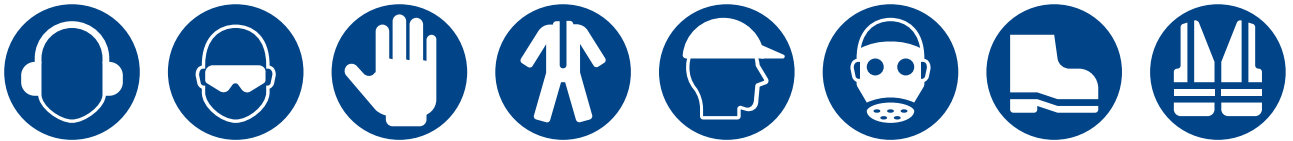

Always wear personal protective equipment and observe the hazards when carrying out the following activities.

5.1 Installation instructions

General installation instructions

Ropes must be replaced due to their limited service life, which is normally significantly shorter than the service life of the system. The installation process differs between the various systems on which the rope is installed. However, the following instructions should be observed regardless of the type of system:

- Avoid counter-bending, observe unwinding and rewinding direction
- Observe the distance between the first incoming rope sheave and the outgoing rope reel (1000 x nominal rope diameter)
- Always use a swivel between the pull-in rope and the new rope.

If these points are observed, some rope damage and consequential damage can be avoided in advance.

Rope installation: Rope installation must be carried out with the necessary caution and work safety when installing a rope. Before installing the rope, check that the rope construction and the direction of lay are correctly aligned with the winch drum and the rope system. The condition and dimensions of the rope grooves in the drums and sheaves must be checked to ensure that the requirements of ISO 16625 are met. If the new rope is pulled in with an auxiliary rope of smaller diameter, a rotation-resistant rope construction or a synthetic auxiliary rope with high rotational stability should be selected. If the new rope is pulled in with the old rope, a mounting eye should be welded to the rope ends in order to connect them securely

to a strand or a thinner rope. Twists from the old rope can be transferred to the connecting strand or the thinner connecting rope during the pulling-in process without damaging the new rope. Rope socks are often used to pull in ropes. To ensure safe use of these rope socks, the rope ends held by the rope socks should be wrapped with a bind-off. This increases adhesion and prevents possible slipping. A strand or a rope with a smaller diameter can be used as a connecting rope.

5.2 Installation

New rope and old rope with the same diameter

New rope and old rope with the same diameter

Rope sock



Coupler rope with wire rope clips EN 13411-5

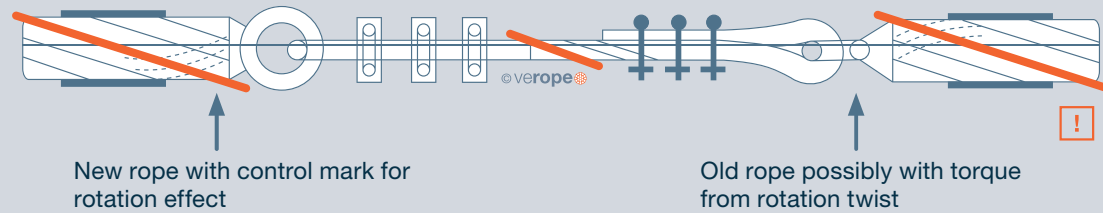

New rope with control mark for rotation effect

Old rope possibly with torque from rotation twist

Tie-offs with at least $2 \times d$ length per side

Auxiliary rope with smaller diameter

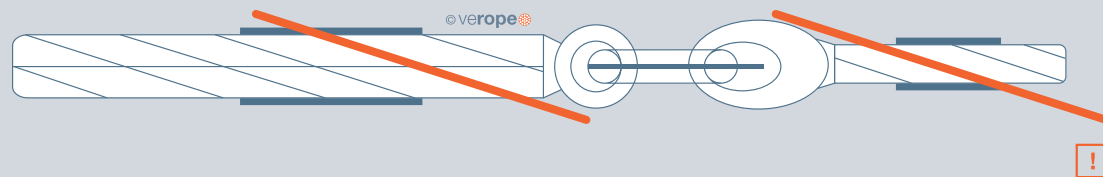

! ONLY CONNECT ROPES WITH THE SAME LAY DIRECTION !

Fig. 34: Rope sock

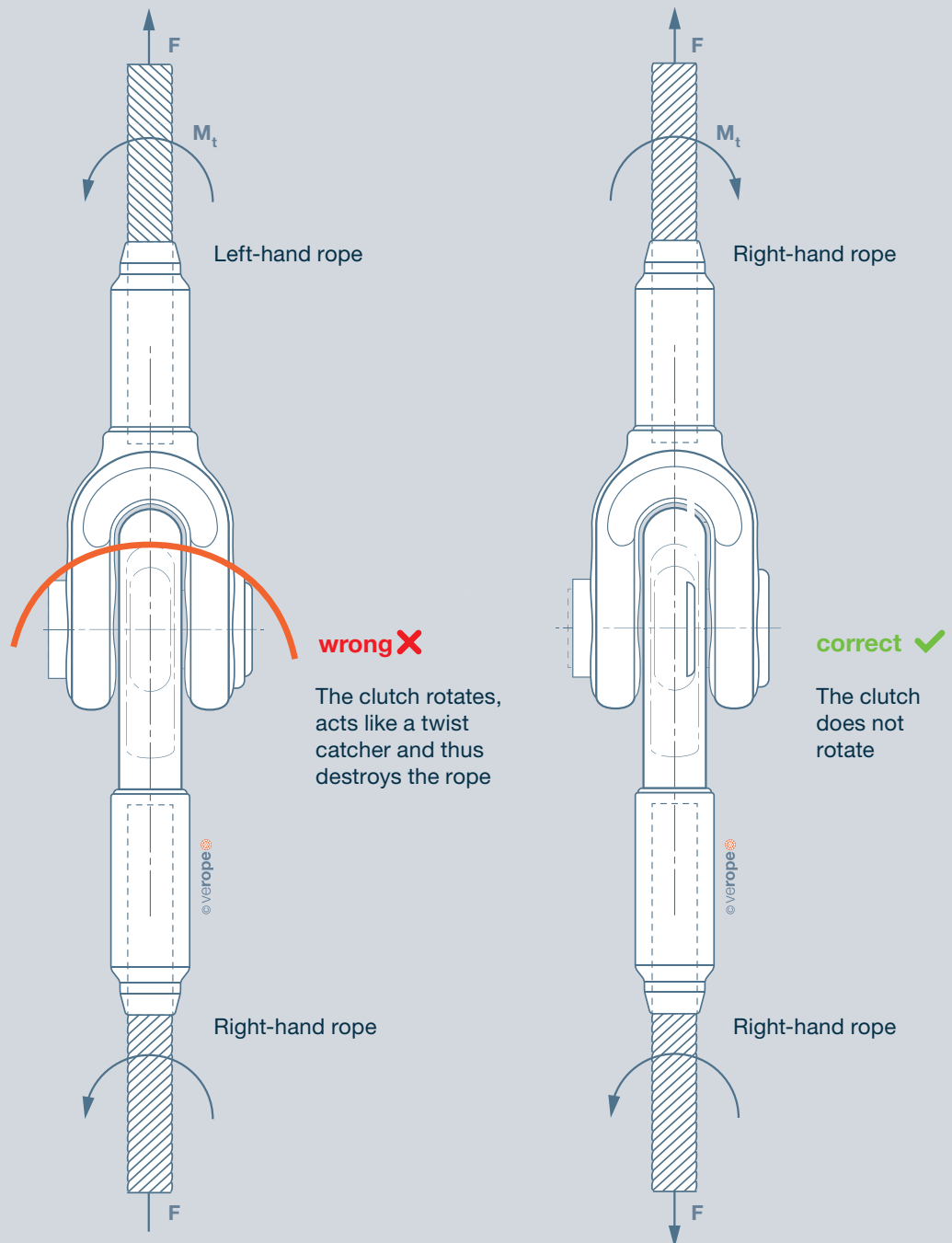

Fig. 35: Coupling of non-rotation-resistant ropes

Rope installation

The rope installation must be prepared as well as possible.

The following points must be observed:

Notes

- If possible, do not guide the wire rope with your hands
- Observe national work and product safety regulations
- Clearly mark or cordon off the work area
- Guide or secure the wire rope in such a way that tripping hazards are prevented
- Do not lay out the wire rope in traffic and footpaths

Checking the new rope

The new rope must be checked with regard to construction and lay direction, and the current rope diameter must be measured. This information should be compared with the delivery documents. The following diagram shows the correct assignment of the rope rotation, right-hand or left-hand rope, to the existing drum, which winds the rope up or down. Drums can be divided into right-handed and left-

handed. The tried and tested rule for selecting the correct rope is that a right-handed rope is used on a left-handed drum and vice versa. This applies in particular to all single-layer drum systems. We also recommend observing this rule for multi-layer winding drums.

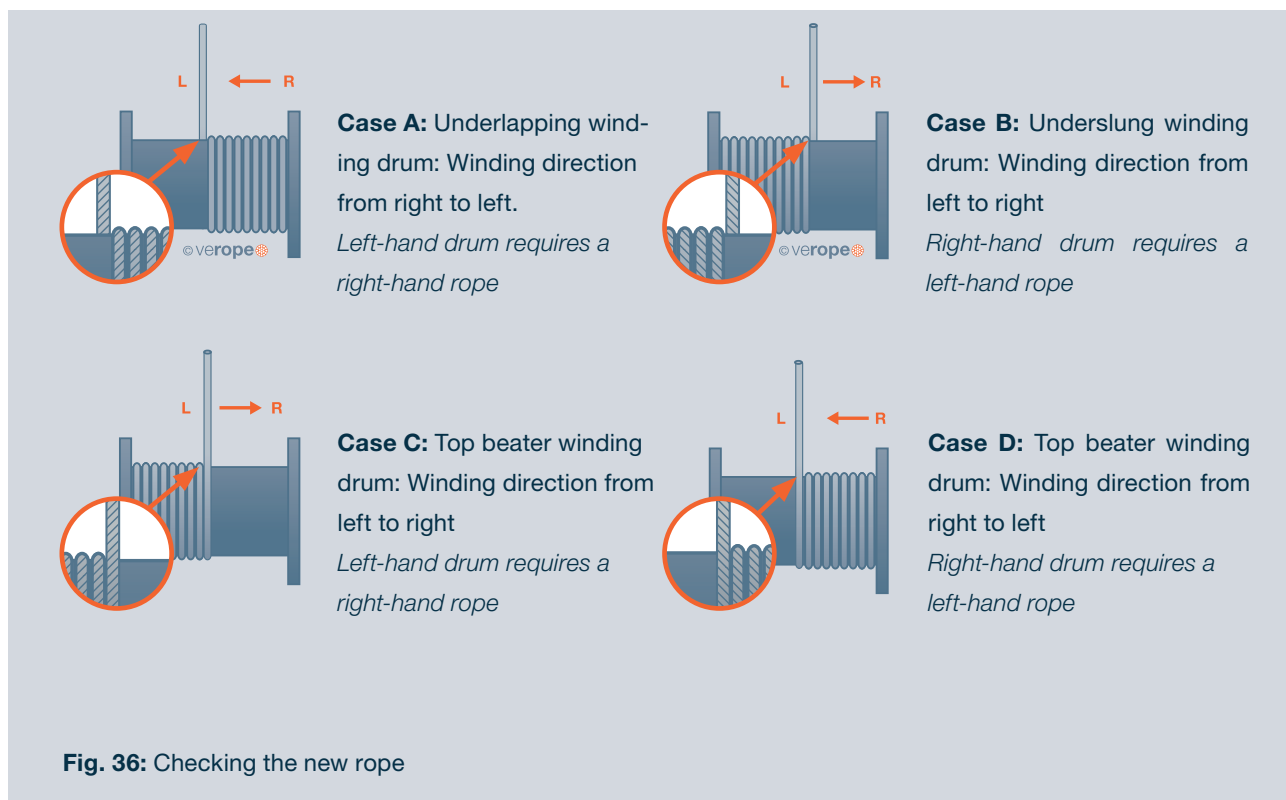

Disassembly

- Improper disassembly can lead to injuries
- Ropes may only be dismantled by appropriately qualified personnel.

5.3 Installation examples

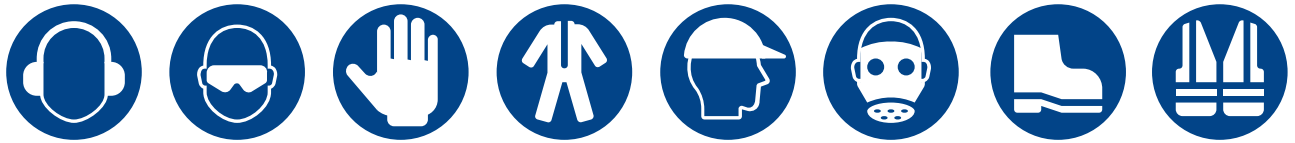

Deck crane installation example

The installation process

The most advantageous way to install a wire rope varies from crane to crane. In any case, a method should be selected that can produce the least risk of rope twisting or damage to the rope (at a reasonable cost). If you unwind the rope from the delivery reel, the delivery reel must be designed to rotate. Unwinding the new rope from a stationary reel or non-rotating reel will cause the rope to twist and the rope can be destroyed during installation. With some cranes, it may be advisable to remove the old rope first and then install the new rope. On other cranes, especially larger cranes, it may be better to attach the new rope to the old rope and pull it in.

Another option is to use a thinner rope as a pull-in rope, which is then used to pull the actual wire rope into the system later. This method is often used on new devices. In any case, careful consideration should be given to whether the wire rope should be pulled through the entire reeving system or whether it should first be wound from the reel onto the drum and then pulled into the system.

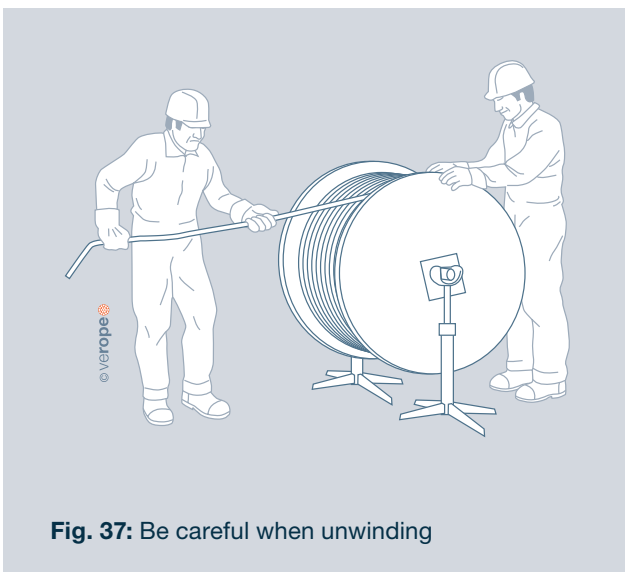

Fig. 37: Be careful when unwinding



!! Be careful when rewinding, hands can be pinched !!

Typical example of a deck crane

An example of a typical deck crane is shown on the right, in which the rope is pulled from the rope reel over the rope sheaves into the reeving and wound onto the rope drum. It must be ensured that the rope surface is clean and that no sand or dirt adheres to the rope lubricant. A dirty rope can damage the wires when running over the sheaves and significantly reduce the effectiveness of the lubricant.

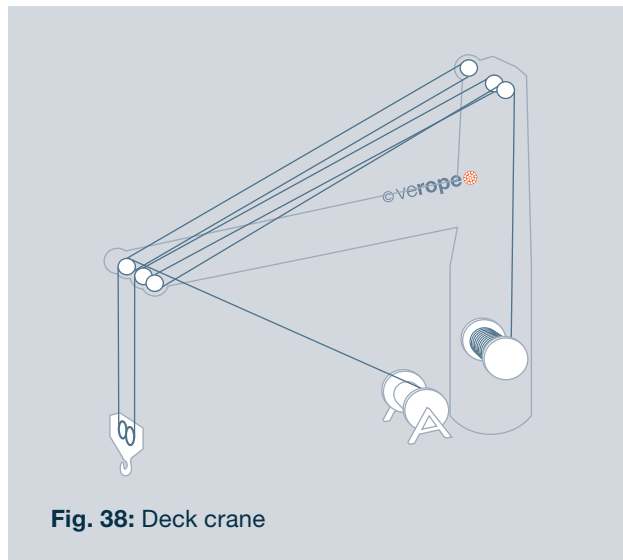

Fig. 38: Deck crane

Installing the new rope using the old rope or a thinner rope

If the new rope is pulled by the old rope or by a thinner rope, it must be ensured that the connection between the ropes is absolutely secure. It must also be ensured that the thinner rope cannot rotate or twist. For example, rotation-resistant ropes must be pulled in using the same rotation-resistant ropes or four-strand ropes with low rotation resistance. When installing non-rotation-resistant ropes, it must at least be ensured that the new and old ropes have the same lay direction. In all cases, it is helpful to fit a small rope swivel between the rope ends to remove any possible twist. If the new rope is pulled in with the help of

the rope used, the two rope ends are often blocked. Such a connection can transfer the twist of the old rope, which is in the system, to the new rope. This type of installation can damage the new rope even before it is used for the first time. There are other reasons why this method is very problematic: when using welded mounting eyes, these can be overloaded by the twisting forces and break.

Attaching the rope end connection to the fixed point

After the rope has been pulled through the reeving, the rope end connection must be brought to the fixed point. Using a chain hoist, the rope end connection can be pulled up to the fixed point and secured there with a bolt. Before fastening, the rope end connection can be precisely aligned with the fixed point using a steel rod. The rod should

be attached to the rope with a short chain. Under no circumstances should the rope be gripped with a wrench or pliers, as this could damage the outer wires.

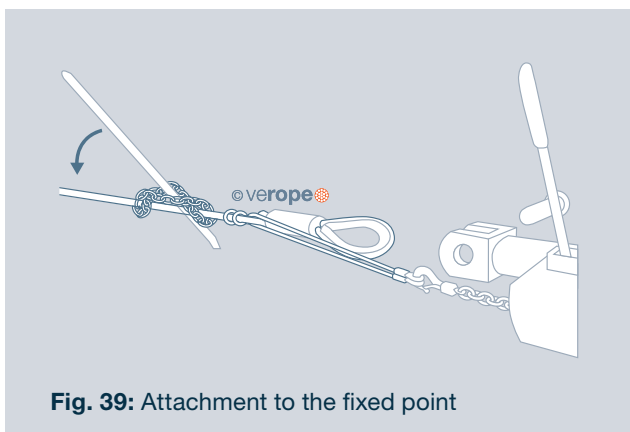

Fig. 39: Attachment to the fixed point



!! Take care when releasing fixed points, rope ends can fall over !!

Working in the new special wire rope

After the rope has been installed and before it fulfills its task, several runs of the normal operating sequence should be carried out under light load. The new rope should be „worked in“ so that the elements can settle and adapt to the actual operating conditions. Unfortunately, the exact opposite often happens in practice. It is not uncommon for overload tests to be carried out after the rope has been installed with loads that exceed the normal working load of the system. As a result, the ropes are not adapted to the operating conditions and uncontrollable tensions or twists can form in the rope.

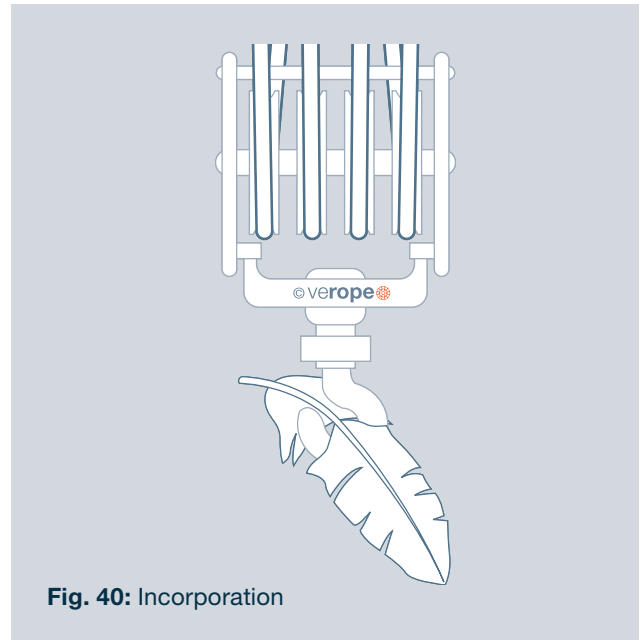

Fig. 40: Incorporation

Mobile crane installation example

Many crane manufacturers work with special rope diameter tolerances. These must always be observed in order to achieve the best rope performance.



Winding on the new rope

If you unwind the rope from the delivery reel, the delivery reel must be designed to rotate. Pulling the new rope off a stationary reel or non-rotating reel will cause the rope to twist and the rope can be destroyed during installation. It must also be ensured that the rope surface remains clean and that no sand or dirt adheres to the rope lubricant. A dirty rope will damage the wires when the rope runs over the sheaves. The following illustrations show the correct

and incorrect way to unwind a rope. Special care must be taken to ensure that the rope does not come into contact with parts of the steel structures or other fixed parts. The deflection angle between the delivery reel and the first pulley of the crane must not exceed 2°.

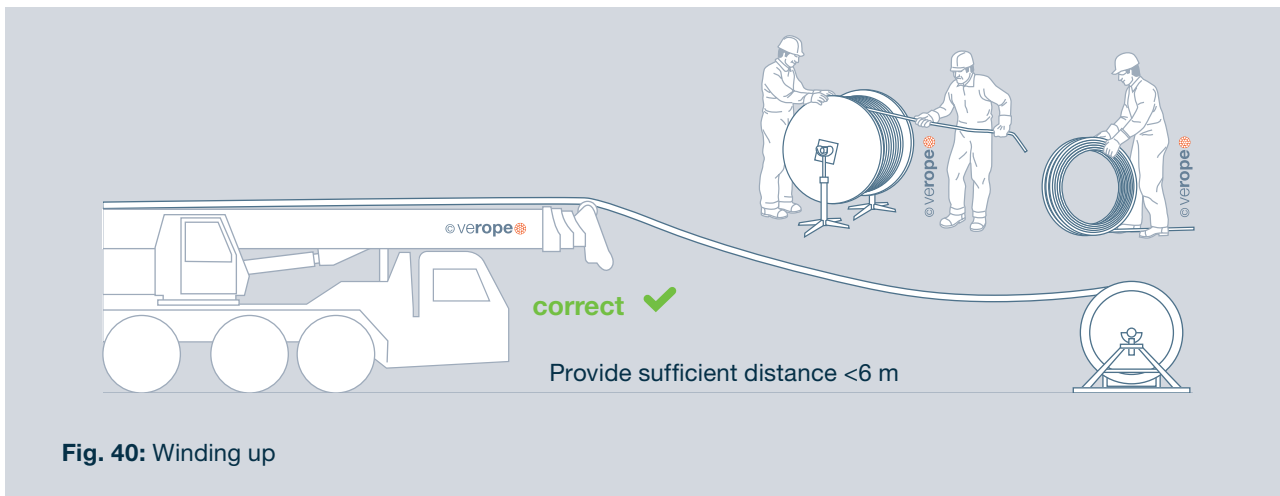

Fig. 40: Winding up

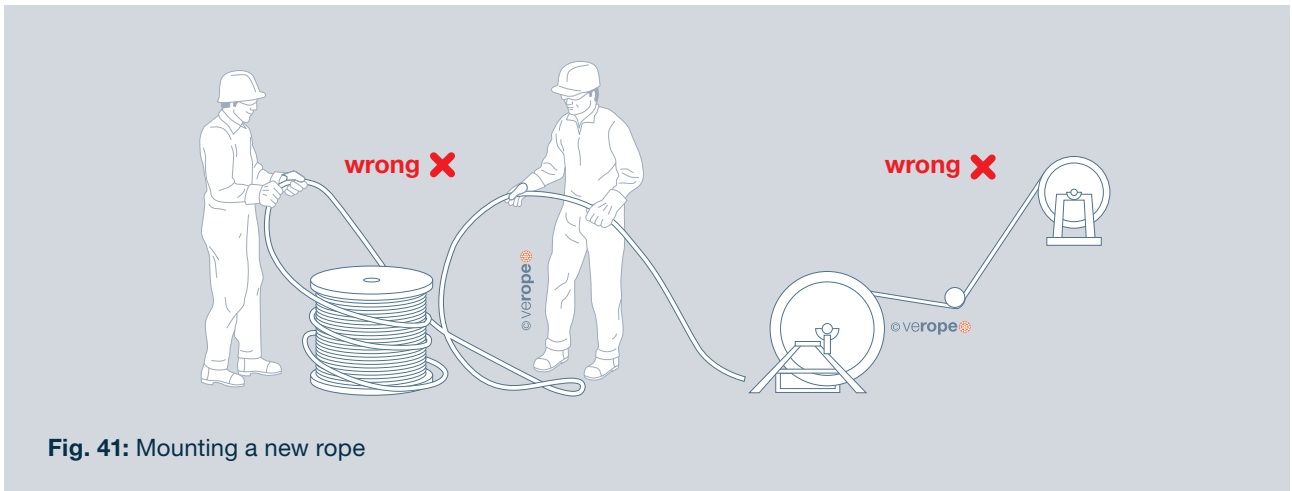

Fig. 41: Mounting a new rope



!! Be careful when rewinding, hands can be pinched !!

Spooling the rope onto the drum

Ensure that the rope is sufficiently pre-tensioned on the drum for rope installation. Renew the pre-tension at regular intervals so that all rope layers can work together firmly as a „package“. This can be done in the field as follows: Extend the boom far enough or reeve high enough so that you can unwind the entire length of rope up to the 3 safety windings on the drum. Now lift a sufficient load so that the rope is spooled with sufficient pre-tension of at least 2.5% of the MBL or 10% of the SWL from the first drum position. This procedure is also necessary if the crane has only worked with a part of the total rope length. The starting and

stopping movements of the drum cause the rope layers to shift on the lower layers and become loose. If the pre-tension of the rope on the drum is too low, the individual layers become loose and the rope strands running under tension can be pulled into the loose drum layer. This causes the rope to be crushed and severely damaged.

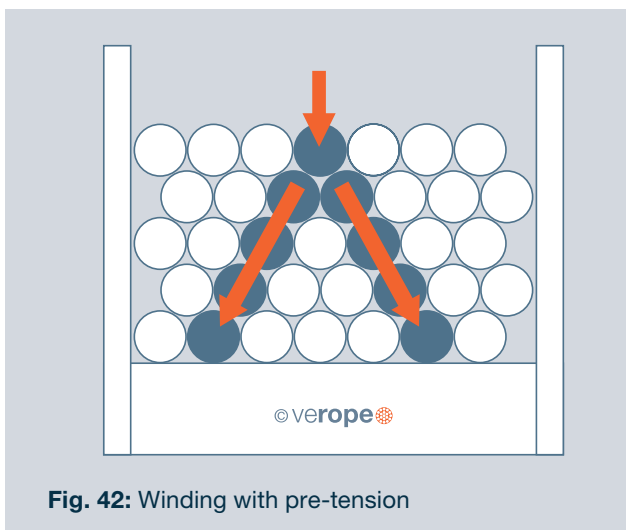

Fig. 42: Winding with pre-tension

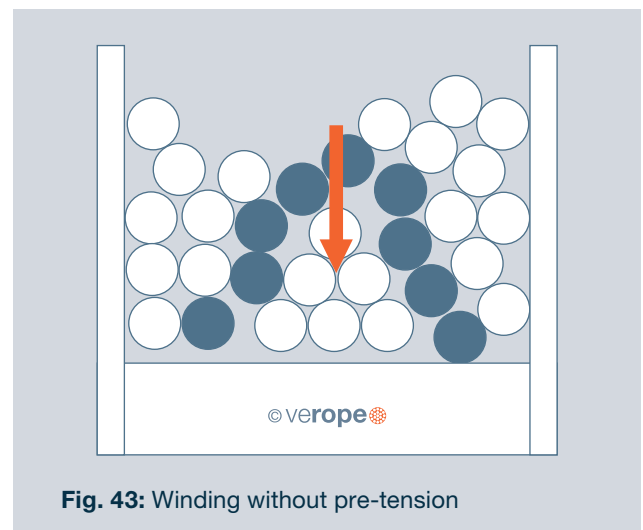

Fig. 43: Winding without pre-tension

5.3 Problem solving

Rope reeving and rope twisting

When reeving the rope, ensure that the strands are evenly distributed in the hook block. If the reeving is unevenly

distributed, the hook block will be skewed and the rope will twist.

Fig. 44:

Reeving wrong

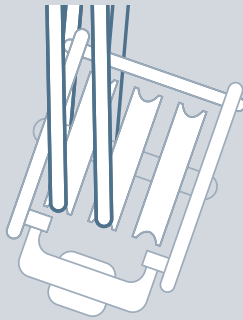

wrong ✘

Uneven distribution of the rope strands

Fig. 45:

Correct reeving

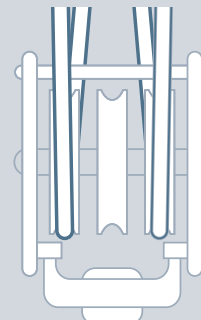

correct ✔

Equal distribution of the rope strands

Twisting of the hook block

There are several reasons why a hook block can twist:

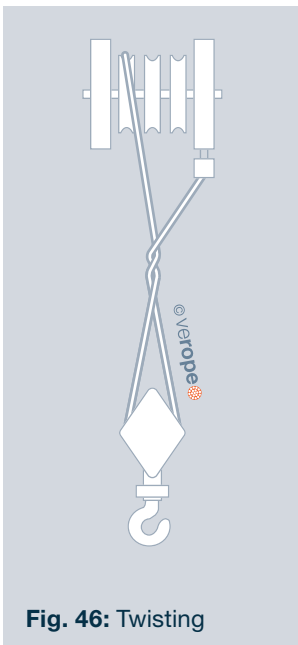

Fig. 46: Twisting

1. The reeving of an odd number of rope strands is significantly less stable than the reeving of an even number of rope strands. A 3-strand reeving is less stable than a 4-strand reeving.
2. A torque or rope twist was applied to the rope during installation.
The maximum permissible deflection angle of 2° was often exceeded here.
3. The load center of gravity is not under the hook
4. Incorrect or uneven attachment when using a double hook.
5. Inclined or poorly balanced hook block.
6. Worn or too narrow groove profiles on the rope pulleys.
7. Poor rope lubrication or relubrication.
8. Diagonal pull during load suspension ($>2^\circ$).
9. Incorrect reeving of the rope with deflection angles $>2^\circ$.
10. Skewed position of the crane.
11. Handling operation (always the same activities with a high number of repetitions).



Untwisting of twisted ropes with rotation-resistant ropes

Method A:

Detach the end of the rope from the fixed point. Rotate the rope end in the opposite direction to the direction of rotation of the hook block. If the hook block rotates by 1/2 turn, rotate the rope end by 180°. If the hook block twists 3 full turns, turn the end of the rope around itself 3 times against the direction of twist of the hook block. Reattach the rope end and guide the rope (without load) through the entire reeving by lifting the hook block. This distributes the twists over the entire length of the rope and significantly reduces them. If the hook block still twists, the procedure must be repeated.

Method B:

When using rotation-free ropes such as verotop, verotop S or verotop E, a rope swivel can also be installed between the fixed point and the crane. This swivel absorbs possible twists or eliminates twists that are already in the rope. Once the twist has been removed from the rope, the swivel can be blocked, completely removed or remain permanently installed. After installing a new rope, the rope should be moved several times under low load and at reduced speed with the boom fully extended. Repeat this several times with increasing load and speed. This allows the rope to adapt to the working conditions and all strands and wires to settle into a neutral position. Ideally, you should loosen the end of the rope again after the running-in period to release any torques and twists that have built up during installation and the running-in period.

If you have any questions, uncertainties or problems, please contact verope® AG

Commissioning

Commissioning may only be carried out by trained personnel.

Running in the new rope – ISO 4309

Before fully commissioning the rope on the crane, it must be ensured that all hoist limiting and display devices for crane operation are working properly.

To allow the rope components to adjust better to the normal operating conditions, the crane should be operated at a reduced speed and load for a certain number of operating cycles [i.e. at approx. 10 % of the maximum rope pull or the maximum load capacity of the machine.

6 INSPECTION AND PERIODIC MAINTENANCE

Personal protective equipment must be worn for the following work and local safety regulations must be observed.



6.1 Types of inspection

The right rope inspection

Why inspect ropes?

Ropes in rope drives are open gears that are exposed to external influences, but also have common signs of wear. Above all, however, ropes have a limited service life. When the rope reaches discard maturity, it has also reached the end of its service life. Rope discard must be detected in good time in order to avoid accidents such as rope

breakage. This detection requires regular rope inspections that document the percentage of the rope used that is already ready for discarding.

A meaningful rope inspection should take the following points into account:

- General visual inspection (points requiring increased attention)
- Diameter measurement with a suitable tool and at various points - Measurement of the rope lay length
- Assess the degree of corrosion (if present)
- Inspect and classify the most stressed rope zone for wire breaks
- Measure the groove diameters in the rope drive
- Assess the amount of lubricant on the rope surface

Such inspections must be carried out regularly, although the intervals between the various points may vary. A visual inspection should be carried out daily, but the diameter

should be measured monthly or quarterly, depending on the load. In principle, the current standards such as ISO 4309 should be followed.

General visual inspection and daily visual inspection

A general visual inspection, which must be carried out by the crane driver or system operator, is intended to detect obvious damage such as broken strands or faults in the reeving at an early stage and, if possible, to rectify them

before operation commences. Areas near the end connection and rope zones that could come into contact with the crane structure and the rope drum must be inspected with increased attention.

Regular inspection

The regular inspection must be carried out by a competent person. The entire crane system should be monitored and maintained.

Examples from practice

- Measurements to be carried out quarterly: Diameter and lay length
- Annual measurements: Groove size, sheave depth, hardness of sheaves and drum (optional)

6.2 Tools required for the inspection

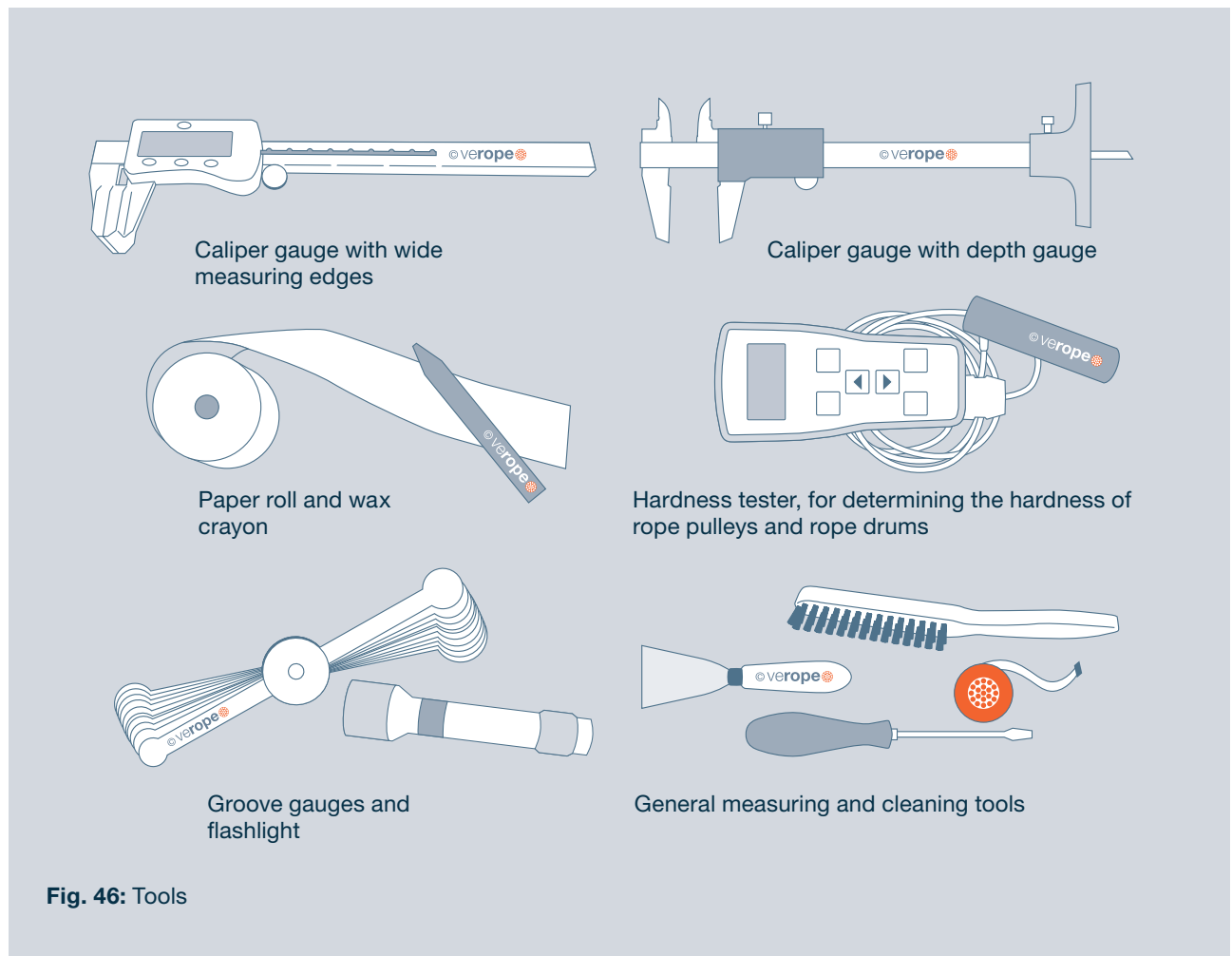

6.3 Discard criteria

Wire breaks on the rope surface

Wire breaks on the rope surface can be caused by bending stress on the rope when running over sheaves or wear. The number of wire breaks must not exceed a certain number over a defined length, otherwise the rope has reached discard maturity.

Wire breaks due to bending fatigue stress can multiply quickly and occur randomly.



!! Protruding wires can lead to injuries !!

Number of permitted wire breaks for non-rotation-resistant ropes

verope® special wire rope construction	Nominal rope diameter d (mm) ⁷	Number of load-bearing wires in the outer strands	Rope category RCN according to ISO 4309	Stripping wire breaking number according to ISO 4309 ¹					
				For applicable rope ranges see footnote ²			For applicable rope ranges see footnotes ^{3,4}		
				Classes M1 to M4 or class unknown ⁵			All classes M1 to M8		
				Cross stroke		Equal stroke		Cross and equal stroke	
				over a length of				over a length of	
				6 x d ⁵	30 x d ⁵	6 x d ⁵	30 x d ⁵	6 x d ⁵	30 x d ⁵
verostar 8 veropro 8 veropro 8 RS verosteel 8	up to 42 43 to 48 larger than 48	208 248 288	09 11 13	9 10 12	18 21 24	4 5 6	9 10 12	18 20 24	36 42 48
veropower 8	up to 40 41 to 46 larger than 46	208 248 288	09 11 13	9 10 12	18 21 24	4 5 6	9 10 12	18 20 24	36 42 48
verotech 10 veropro 10	16 mm to 50 mm	260	11	10	21	5	10	20	42

Please contact verope® directly for rope constructions that are not included.

Number of permissible wire breaks for rotation-resistant ropes

verope® special wire rope construction	Number of load-bearing wires in the outer strands	Rope category RCN according to ISO 4309	Stripping wire breaking number according to ISO 4309 ¹			
			For applicable rope ranges see footnote ²		For applicable rope ranges see footnotes ^{3,4}	
			over a length of		over a length of	
			6 x d ⁵	30 x d ⁵	6 x d ⁵	30 x d ⁵
vero 4	144	22	2	4	4	8
verotop XP	96	23-1	2	4	4	8
verotop verotop S verotop S+ verotop E	112	23-2	3	5	5	10
verotop P	126	23-3	3	5	6	11

Degree of corrosion

Ropes that work in certain environments or have an increased service life begin to corrode. A distinction is made between different degrees of corrosion. ISO 4309 provides a generally applicable differentiation.

Guideline for the assessment and classification of external corrosion

Guideline for the assessment and classification of external corrosion



1. Beginning oxidation of the surface, can be washed off, only on the surface.
Classification: 0 % of the discard maturity.



2. wires feel rough, general oxidation of the surface.
Classification: 20 % of the discard maturity.



3. Surface heavily oxidized.
Classification: 60 % of the discard maturity.



4. Surface badly pitted, wires without tension, gaps between wires. Immediate storage.

Fig. 46: Corrosion

Diameter reduction

The rope diameter of a working rope is constantly reduced over its entire service life. This reduction in diameter is caused by abrasion and wear and is assessed according to the following table and classified up to the point of discard.

Rope type		Uniform reduction in diameter (expressed in % of the nominal diameter)	Classification of the degree of severity	
			Description	%
© verope  Non-rotation-resistant ropes	verostar 8	less than 3.5 3.5% or more, but less than 4.5 4.5% or more, but less than 5.5 5.5% and over, but less than 6.5 6.5% and over, but less than 7.5 7.5% and over	–	0
	veropro 8		light	20
	veropro 8 RS		medium	40
	veropower 8		high	60
	veropro 10		very high	80
	verotech 10		Discard maturity	100
Rotation-free ropes	verotop	less than 1% 1% or more, but less than 2%. 2% or more, but less than 3%. 3% or more, but less than 4%. 4% and more, but less than 5%. 5% or more	–	0
	verotop S		light	20
	verotop S+		medium	40
	verotop E		high	60
	verotop P		very high	80
	verotop XP		Discard maturity	100
	vero 4			

The following formula is used to determine the diameter reduction:

$$\Delta d = \left[\frac{d_{ref} - d_m}{d} \right] \times 100 \%$$

Example:

A non-rotation-resistant rope with a nominal diameter of 22.00 mm has a reference diameter (rope diameter in new condition) of 22.80 mm and a measured diameter of 21.90 mm.

The following applies:

$$\left[\frac{22,80 - 21,90}{22} \right] \times 100 \% = 4,1 \%$$

The rope has reached 20 % discard maturity after diameter reduction.

Inspection report:

The ISO 4309 inspection report provides helpful support. This report lists all the relevant points of a structured rope inspection.

Another way to document the rope inspection is in the ver-ocheck app. To do this, download the app from the App Store and contact your verope® contact person for approval.

Information on the crane:						Rope application:					
Details of the rope: Brand (if known): Nominal diameter (mm): Type: Core ^a : IWRC FC WSC Wire surface ^a : bright galvanized						Laying direction and type ^a : (right hand side): sZ ZZ Z / (left hand side): zS sS S Permissible number of outer wire breaks: 6 d 30 d Reference diameter (mm): Permissible diameter reduction from reference diameter (mm):					
Hang-up date:						Discard date:					
Visible outer wire breaks				Diameter			Corrosion	Damage and / or deformation		Position in the rope	Overall assessment, i.e. combined severity classification ^b at the position entered
Quantity in length from		Severity classification ^b		Measured diameter	Actual reduction compared to Reference diameter	Severity grading ^b	Severity grading ^b	Severity grading ^b	Type		
6 d	30 d	6 d	30 d	in mm	in mm						
Further remarks:											
Performance on the date indicated (cycles, hours, days, months, etc.):						Date of inspection:					
Name of competent person:						Signature:					
<small>^a If applicable, check the box ^b Description</small>											

Fig. 47: Inspection report

6.4 Other rope damage

Miscellaneous rope damage



Rope deformations can lead to injuries!

Further information on inspecting the system can be found in the brochure „Correct handling of verope® special wire ropes“ or ISO 16625.



7 MAINTENANCE

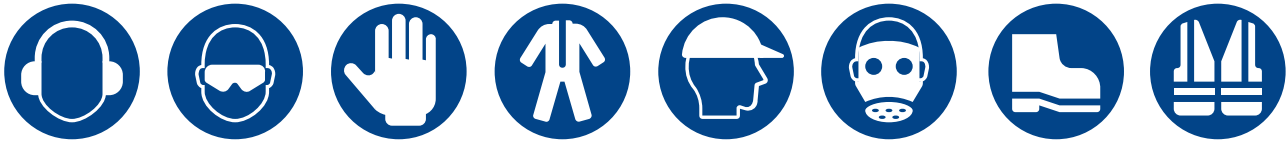

Personal protective equipment must be worn for the following work and local safety regulations must be observed.

7.1 Maintenance of the rope

Maintenance of the rope must be carried out taking into account the crane type, frequency of use, environmental conditions and rope type.

During its service life and before it shows any signs of dryness or corrosion, the rope must be relubricated as specified by a competent person for wire rope inspection, in particular by a qualified rope inspector.

The rope must be relubricated during its service life and before it shows any signs of dryness or corrosion, as determined by a competent person for wire rope inspection, especially in the zones that run over sheaves, run onto or off the drum, or the sections that run over compensating sheaves.

For more information, refer to ISO 4309.

7.2 Relubrication of special wire ropes



!! Take care when relubricating by hand,
Hands can get jammed or caught !!

Types de lubrifiants

In principle, verope® uses two types of lubricants, namely wax-based and oil-based agents. The choice of basic lubricant depends on the application, rope type and place of use. There are also lubricants that are used in areas with special requirements such as water solubility, drip resistance or nature conservation guidelines. The range of lubricants is just as diverse as the various applications. In order to increase the service life of the rope and protect the inside of the rope, the lubricant film on the rope surface must remain constant. Lubricant is usually lost during

operation and must be reapplied at regular intervals. When selecting a suitable relubricant, the existing base lubricant must be used, as otherwise compatibility problems may occur. If you are unsure which lubricant your verope® special wire rope uses, we will be happy to advise you.

Quantity and frequency of relubrication

We generally recommend relubricating the rope 10 times over its entire service life. For applications that have a comparatively short service life (e.g. due to high and rapid wear), the rope must be relubricated 10 times after use.

$$\frac{\text{Rope weight} \frac{\text{kg}}{\text{m}} \times \text{rope length m}}{100} = \text{Lubricant quantity kg}$$

Preparing the rope to be relubricated

The rope must be prepared so that the relubrication and the newly applied preservative can fulfill their full function. Applying the lubricant without prior treatment covers the existing lubrication, which has often dried out and no longer has any lubricating effect. In addition, a rope that is free of surface dirt is easier to inspect so that possible defects are easier to detect. There are various ways to remove the existing lubricant from the rope surface. There is a cleaning system that uses rotation and translation to remove the dirt from the rope surface. Another conventional method of removing the lubricant from the rope surface is the use of steel wire brushes. Here, the lubricant is scraped off the

Application of the relubricant and the different methods

Once the old lubricant has been removed from the rope surface, the new lubricant is applied. Various methods and procedures can also be used here. There are various companies that offer complete solutions for reforging. The principle of this method differs only in appearance. The rope is enclosed with the help of a sleeve. There is a cavity in the sleeve into which the lubricant is pressed under high pressure. Excess lubricant is removed at the end using a scraper.

Many applications, such as container gantry cranes, have automatic re-spraying devices that continuously re-grease the rope. This type of relubrication is used when the system cannot be shut down for time or cost reasons or when the need for lubricant is increased. This application can be retrofitted by specialized companies without any problems. Another cost-effective method is

relubrication as required. The quantity of relubricant to be applied can be defined by the following equation:

rope surface by relative movements on the rope surface. The more lubricant is removed from the surface, the better the effect of the new lubricant. This method requires a great deal of force and is very time-consuming, depending on the length of the rope. Nevertheless, this procedure is very effective if no other method is available.

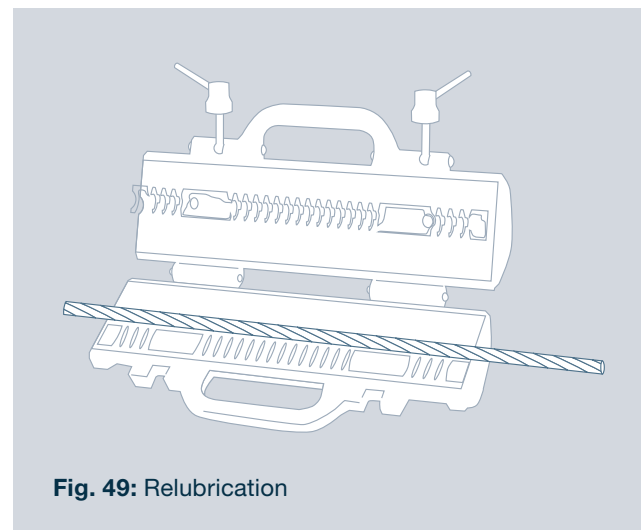

Fig. 49: Relubrication

manual application. Here, either atomizer systems using compressed air can be used, or simple tools such as brushes or soaked cloths can be used. With this method, care must be taken to ensure even application.

Both too much and too little lubricant are counterproductive. The best effect is achieved with a very even film of lubricant. Lubricants are also available in aerosol cans for re-preservation. The practical aerosol cans allow an even mist to be applied to the rope. The propellant gas

in the can evaporates, leaving pure lubricant on the rope. verope® also offers a lubricant in aerosol cans for special wire ropes. Our verolube® can be purchased on request.



!! Heated rope lubricant can cause injuries !!

7.3 Removal of ends of broken wires

With some wire breaks, the broken wire may protrude from the rope. This wire can damage neighboring wires when it runs over the sheave again, causing secondary wire breaks. By using pliers and continuously bending the

protruding wire back and forth, it can be removed and no longer poses a risk to neighboring wires.



!! Protruding wires can cause injuries !!

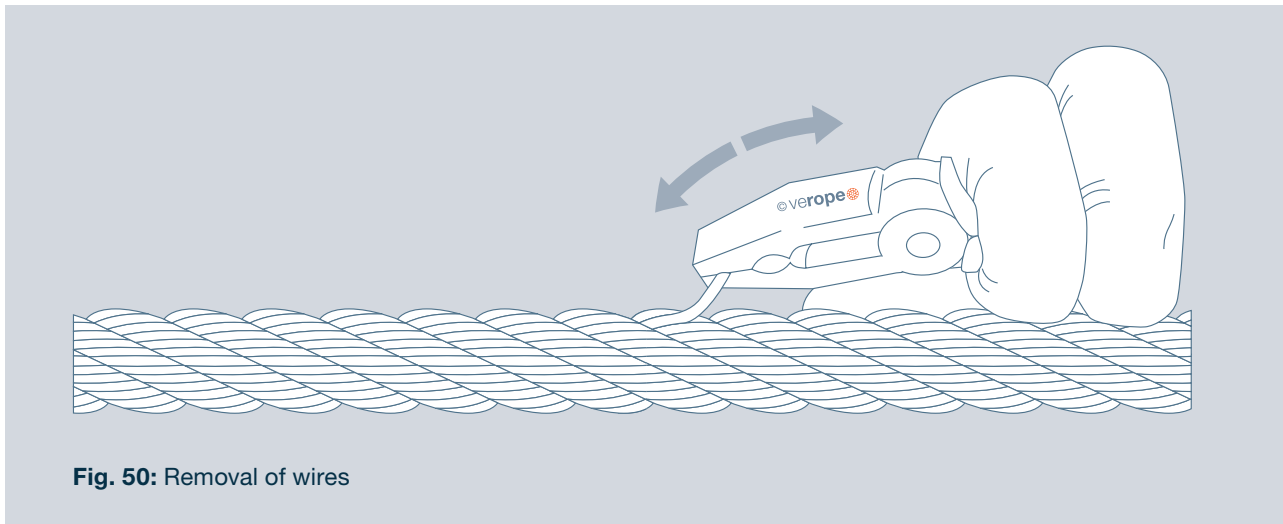

Fig. 50: Removal of wires

7.4 Replacing the rope / dismantling Decommissioning

A rope must be replaced by qualified or authorized persons in compliance with the applicable regulations.

Disassembly

- Improper disassembly can lead to injuries.
- May only be carried out by suitably qualified personnel.
- Only qualified specialist personnel who are familiar with the ISO 4309 and EN 12385 standards

standards may decommission ropes or systems.

- The following knowledge is also required:
 - Safety regulations concerning ropes
 - Assembly and disassembly instructions

Special protective measures when dismantling ropes

! when removing damaged wire ropes, these can tear during replacement / exchange.

! when removing worn wire ropes with damaged / protruding wires

! permanent deformations or twisted parts can lead to injuries.

! verope® special wire ropes, which work with plastic rope pulleys or non-metallic rope pulleys, have special discard criteria. Check the information in the user manual for the system or contact the manufacturer.

! Note the data and the reason for replacement on the product certificate.

! Keep discarded wire ropes in a safe place and label them so that they are no longer used.

! Dispose of the rope in accordance with local regulations.

8 WARRANTY / TERMS OF BUSINESS ETC.

GENERAL TERMS AND CONDITIONS

of verope® AG (as of July 10, 2009)

1. Scope of application

1.1 These General Terms and Conditions (hereinafter referred to as GTC) shall apply to all deliveries, services and offers of verope® AG with its registered office in CH-6300 Zug, Switzerland (hereinafter referred to as Seller), unless they are expressly amended or excluded in writing. Deviating general terms and conditions are not recognized and do not form part of the contract even without express written objection by the seller.

2. Conclusion of contract, prices, packaging costs, shipment, transport insurance

2.1 Offers made by the seller are non-binding. The contract shall be deemed concluded when the Seller has sent a written declaration of acceptance or order confirmation following an order, if applicable within the period set by the Buyer. If the seller has set a deadline for acceptance when submitting a written and binding offer, the contract shall be deemed to have been concluded if the buyer has sent a written declaration of acceptance before the deadline expires, provided that this is received within three days of the deadline expiring at the latest.

2.2 The documents belonging to an offer, such as illustrations, drawings, weight and dimension specifications, performance and other property descriptions as well as other information on contractual products and services are only approximately binding. The seller's catalogs are constantly being revised. We reserve the right to make product changes. Certain properties of the goods to be delivered shall only be deemed guaranteed if this has been expressly agreed in writing. A reference to standards or agreed specifications or to the seller's catalog of goods alone merely contains a more detailed description of the goods or services and not a guarantee of properties.

2.3 All prices are ex works of the producer designated by the Seller plus customs duties, levies, value added tax, sales tax and the like, and plus packaging (cf. 3.1). We reserve the right to increase prices due to material or labor cost taxes. In the absence of a special agreement, packaging shall be at the seller's discretion and at cost price.

2.4 Goods shall be shipped at the expense and risk of the Buyer. Transport insurance shall only be taken out at the special request of the Buyer and at the Buyer's expense.

3. Delivery, transfer of risk

3.1 Unless otherwise agreed in writing, deliveries shall be made ex works of the producer designated by the Seller (EXW Incoterms 2000 - see No. 2.3). Clauses agreed to the contrary shall be agreed and interpreted in accordance with the relevant Incoterms of the International Chamber of Commerce in Paris.

3.2 Partial deliveries are permissible and shall be paid for pro rata.

3.3 In the case of export contracts, the buyer shall assume the warranty for shipment to the foreign customs territory and use there. He shall provide the corresponding proof upon request.

3.4 Benefit and risk shall pass to the Buyer upon provision of the goods ex works of the producer designated by the Seller at the time of delivery, but at the latest upon acceptance.

4. Delivery time, delay

4.1 Specified delivery dates are generally non-binding and only binding if this has been expressly agreed in writing. The delivery period shall commence upon dispatch of the order confirmation, but not before the documents, licenses, permits and other formalities to be procured by the Buyer have been provided and the agreed advance payments have been made.

4.2 In the event of a delay in delivery for which the Seller is responsible, the Buyer may, after the expiry of 4 weeks, demand compensation for damages in the amount of 0.5% - but not more than 5% - of the value of the part of the delivery which cannot be used as intended as a result of the delay, to the exclusion of further claims for demonstrable damages.

4.3 Insofar as the maximum amount of damages according to No. 4.2 has been reached, the Buyer may, after setting a reasonable grace period with the threat of refusal of delivery, declare the contract avoided with regard to the delayed part if the Seller does not perform beforehand. No. 7.5 applies accordingly.

4.4 Specifications and call-offs must be made by the Buyer in good time so that the time required for production and delivery is available by the final acceptance date. If a delivery period is agreed in units of time (weeks, months), it shall commence on the date of dispatch of the order confirmation. Amendments to the contract which may affect the delivery time shall result in a reasonable extension of the delivery time. If the Buyer is in default with a material obligation arising from the contractual relationship, the Seller shall be entitled to extend the delivery period by the period of default. No. 5 shall apply accordingly.

5. Acceptance, call-off orders

5.1 Deliveries shall be accepted by the Buyer, even if they have insignificant defects, without prejudice to the Buyer's rights in respect of defects. The Buyer shall bear the costs of storage, insurance, protective measures, etc. incurred as a result of delayed acceptance. Without special proof, he must pay at least 1% of the order value per week of delay, but no more than 5%. The seller may set the buyer a reasonable deadline for acceptance in writing if the buyer does not accept the goods at the delivery time. The seller's right to demand payment of the purchase price remains unaffected. After the expiry of the deadline, the seller may waive the subsequent performance and either demand compensation for the damage resulting from the non-performance or withdraw from the contract in whole or in part and demand compensation.

5.2 Delivery contracts without a fixed delivery date („on call“) are only possible in exceptional cases and with express written agreement. The seller shall confirm the date from which the delivery can be made. In the absence of an express agreement to the contrary, the goods are available on call for a maximum period of one year. After this period, the seller is entitled to deliver. Call-offs must be announced at least 2 weeks in advance.

6. Payment and default of payment

6.1 Unless otherwise agreed, all payments shall be made in advance or by providing an irrevocable and confirmed letter of credit no later than 3 weeks before the delivery date. The Uniform Customs and Practice for Documentary Credits of the International Chamber of Commerce in Paris shall apply. Unless otherwise agreed in writing, all payments shall be made in Swiss francs or in euros, at the seller's discretion, without deduction and free to the seller's paying agent. Bills of exchange or checks shall only be accepted on account of performance.

6.2 In the event of late payment, the Seller shall be entitled to charge interest at a rate of 4% p.a. above the private discount rate from the due date. The seller may suspend the execution of the contract in this respect. If the buyer is in arrears with the payment of the purchase price, the seller may set him a reasonable deadline in writing for subsequent performance. If performance is not effected by the expiry of this period, but at the latest within one month of the due date, the seller may waive the subsequent performance by written declaration and either demand compensation for the damage resulting from the non-performance or withdraw from the contract in whole or in part and demand compensation for damages and reclaim the goods handed over.

6.3 Creditworthiness, default of payment

If special circumstances give reasonable cause to doubt the creditworthiness of the Buyer, all claims arising from the business relationship shall become due immediately and the Seller shall be entitled to demand delivery against advance payment as well as advance payment before production release. Sentence 1 shall also apply if the Buyer is in default of payment under any contract. If partial payment has been agreed and the Buyer remains in arrears with an amount of more than 10% of the outstanding purchase price, the entire outstanding balance shall become due for payment immediately.

7. Responsibility for contractual conformity of the goods

7.1 Duty to inspect and give notice of defects

The buyer must inspect the goods immediately upon receipt. In doing so, he must proceed in accordance with the recognized rules of technology. He shall in any case lose the right to invoke a lack of conformity with the contract if he does not notify the seller in writing immediately after the time at which he discovered it or should have discovered it and describe it precisely. After consultation with the seller, the buyer must ensure that all evidence is secured.

7.2 Handling and storage

Proof of careful handling and proper and dry storage of the goods is the responsibility of the buyer.

7.3 Rectification of defects, replacement delivery

If the goods do not comply with the contract, the Seller may initially rectify the lack of conformity by rectification of defects or replacement delivery within 4 weeks of the Buyer's request, even in the case of significant defects. The rectification of defects may also be carried out by the buyer after consultation with the seller and shall take place at the contractually agreed location of the recipient. If the recipient's location differs from the Buyer's place of business, this must be disclosed to the Seller. Otherwise, the higher costs incurred as a result shall not be borne. The buyer is obliged to cooperate in the rectification of defects within the scope of what is reasonable, against reimbursement of costs and in accordance with the seller's instructions.

7.4 Reduction in price, rescission of contract

If the Seller does not remedy a lack of conformity in accordance with No. 7.3 by repair or replacement, the Buyer may reduce the purchase price appropriately. In the event of a material breach of contract, the Buyer may set a final deadline for performance and demand rescission of the contract if this expires without result.

7.5 Exclusion of compensation for further damage caused by defects

Unless provided for in Clauses 4.2, 4.3 and 7.1 to 7.4, the Seller shall not be responsible for any lack of conformity or damage and shall not be liable for compensation. This applies to any damage caused by defects, including loss of production, loss of profit or other indirect damage (damage that has not occurred to the delivery item itself, such as consequential damage). The Seller shall only be liable for unlawful intent or gross negligence or on the basis of the Product Liability Act.

7.6 Customary deviations, design changes

Deviations in quantities, dimensions, quality, weights and the like are permitted within the scope of what is customary in the trade. We reserve the right to make equivalent design changes and product modifications.

7.7 Compliance with the Seller's instructions

The Buyer shall comply with the Seller's instructions on the further processing or use of the contractual products, otherwise claims for defects shall not be recognized.

7.8 If parts or material are delivered by the Buyer for processing or as a provision for processing an order, no technical suitability test for non-obvious defects shall be carried out unless expressly agreed otherwise.

8. Quantity tolerances, tools, plans, sales documents

8.1 Quantity tolerances of up to 3 % for standard articles of the Seller according to the catalog and up to 10 % for special (customer-specific) parts are permissible.

8.2 Production molds or tools which the Buyer makes available to the Seller for the execution of his order and which are substantially modified by the Seller cannot be reclaimed by the Buyer. The Seller shall be entitled to dispose of such production molds and tools and of tools manufactured for special (customer-specific) parts at its discretion and without compensation after the expiry of one year from the execution of the last order. This shall also apply with regard to an invoiced share of the tool costs. All rights to items not originating from the Buyer shall remain with the Seller, even if the Buyer has assumed acquisition costs.

8.3 All rights to tools, drawings, drafts and plans manufactured by the Seller, in particular patent rights, copyrights and inventor's rights, shall remain the exclusive property of the Seller. All sales documents, such as catalogs, sample books, price lists, etc., which are made available to the Buyer shall remain the property of the Seller and shall be returned upon request (cf. No. 2.2).

9. Responsibility for secondary obligations

The Seller shall only be responsible for the fulfillment of contractual or pre-contractual secondary obligations in accordance with the provisions of Nos. 4, 7 and 11.

10. Non-delivery

If it becomes impossible for the Seller to deliver in whole or in part, the Buyer or the Seller may declare in writing the rescission of the contract with regard to the undelivered part. No. 7.5 and 13 shall apply accordingly.

11. Force majeure

11.1 Each party shall not be liable for failure to perform any of its obligations if such failure is due to any cause beyond its reasonable control or, in particular, to any of the following causes: Fire, natural disasters, war, confiscation export ban, embargo or other official measures, general shortage of raw materials, restriction of energy consumption, labor disputes or if contractual adversities of suppliers are based on one of these reasons.

11.2 Jede Partei darf den Vertrag durch schriftliche Kündigung beenden, falls dessen Durchführung für mehr als 6 Monate gemäß Nr. 11.1 verhindert ist.

12. Other liability of the seller

Unless expressly provided for in these GTC, all further contractual or statutory claims against the Seller, in particular for rescission of the contract, reduction of the purchase price or compensation for damages of any kind, including such damages that have not occurred to the delivery item itself, such as consequential damages, etc., are excluded. No. 7.5 sentences 3 and 4 shall apply accordingly.

13. Statute of limitations

Any claims of the Buyer due to lack of conformity shall become time-barred within six months from the transfer of risk (No. 3). The Seller's liability is limited to breaches of contract that occur within this period.

14. Retention of title

14.1 All delivered goods shall remain the property of the seller until all claims arising from the business relationship have been paid in full. This shall also apply if individual or all claims of the seller are included in a current account and the balance is drawn and recognized. If the validity of the retention of title is subject to special conditions or laws in the country of destination, the buyer is responsible for compliance with them. The buyer is entitled to resell the goods in the ordinary course of business provided that the claims arising from the resale are transferred to the seller as follows. The buyer hereby assigns to the seller all claims with all ancillary rights arising from the resale against the customer or third parties, irrespective of whether the reserved goods are resold before or after processing. The purchaser is authorized to collect these claims even after the assignment. The seller's right to collect the claims himself remains unaffected. The seller undertakes not to collect the claims himself as long as the buyer duly fulfills his payment obligations. The seller may demand that the buyer informs him of the assigned claims and their debtors, provides all information necessary for collection, and makes the claims available to the seller.

14.2 The Buyer shall support the Seller in any measures necessary to protect the Seller's property in the country concerned. The Buyer shall inform the Seller immediately if there are any risks to the Seller's property. This applies in particular to third party seizures or official measures.

14.3 The Seller is entitled to take back the goods subject to retention of title in the event of breach of contract by the Buyer, in particular in the event of default in payment.

14.4 The Buyer shall take out insurance at its own expense for the goods delivered against theft, fire and water damage and other risks for the period until the purchase price has been paid in full.

14.5 If the value of the securities exceeds the claims to be secured by more than 10%, the seller shall release securities of his choice upon request.

14.6 If goods subject to retention of title are combined, processed or transformed, including together with other items not belonging to the Seller, the Seller shall acquire co-ownership of the new item in the amount of the invoice value of the goods subject to retention of title in proportion to the total value of the new item at the time of processing. No. 14.1 to 14.5 shall also apply to the new goods.

15 Miscellaneous

15.1 The Seller is entitled to transfer rights and obligations to subsidiaries and/or trading partners and to assign purchase price claims to banks of the Seller.

15.2 Amendments, supplements and other ancillary agreements to these GTC or to concluded contracts must be made in writing.

15.3 A contract concluded on the basis of these GTC shall remain binding even if individual conditions are invalid.

15.4 The Buyer shall only have rights of set-off or retention in respect of legally established claims.

15.5 Trademarks, trade names, marketing, industrial property rights of the seller

The Buyer may use or register trademarks, trade names and other signs and industrial property rights of the manufacturer or the Seller only after prior written authorization and only in the interest of the Seller.

15.6 Industrial property rights of third parties

The Buyer is responsible for ensuring that his instructions regarding shapes, dimensions, colors, weights, etc. do not infringe the industrial property rights of third parties.

16. Compliance with laws

Compliance with and implementation of the relevant foreign trade regulations (e.g. import licenses, foreign exchange transfer permits, etc.) and other laws applicable outside Switzerland is the responsibility of the buyer.

17. Place of performance, applicable law and place of jurisdiction

17.1 The place of performance for payments by the Buyer shall be CH-6300 Zug/Canton Zug (Switzerland) and for deliveries by the Seller the factory of the producer designated by the Seller.

17.2 These General Terms and Conditions and all contracts concluded under these terms and conditions are subject to the substantive law of Switzerland. The United Nations Convention on Contracts for the International Sale of Goods (CISG) of 11.04.1980 is expressly excluded.

17.3 All disputes arising out of or in connection with contracts based on these GTC shall be settled by the competent state courts at the Seller's registered office.

17.4 The Seller shall in any case also be entitled to bring an action before the courts having jurisdiction for the Buyer's registered office. In this respect, the jurisdiction according to No. 17.3 shall not apply.

9 FOLLOW-UP

We are legally obliged to monitor our ropes even after delivery.

This applies in particular to the following aspects:

- Have there been any changes to the rope design?
- Have production parameters been changed?
- Are there any experiences with the ropes that could be important for other users?
- Are there any malfunctions / failures?
- Are there any abusive applications?
- Are there any difficulties with the operating instructions?

Please let us know what could be important for us.

Simply use the following form and send it to sales@verope.com



You can fill out the form online here

www.verope.com/formblatt/

If you have any questions or comments, please contact verope® AG – e-mail: Info@verope.com.



St. Antons Gasse 4a
CH-6300 Zug ZG
Switzerland
Tel.: +41 58 588 80 880

Tina Kunz

Zug / CH, in March 2024